

			29/07/2019	
0	EMIS		DESSINE	LC
REV	MODIFICATION	29/07/2019	APROUV	SP

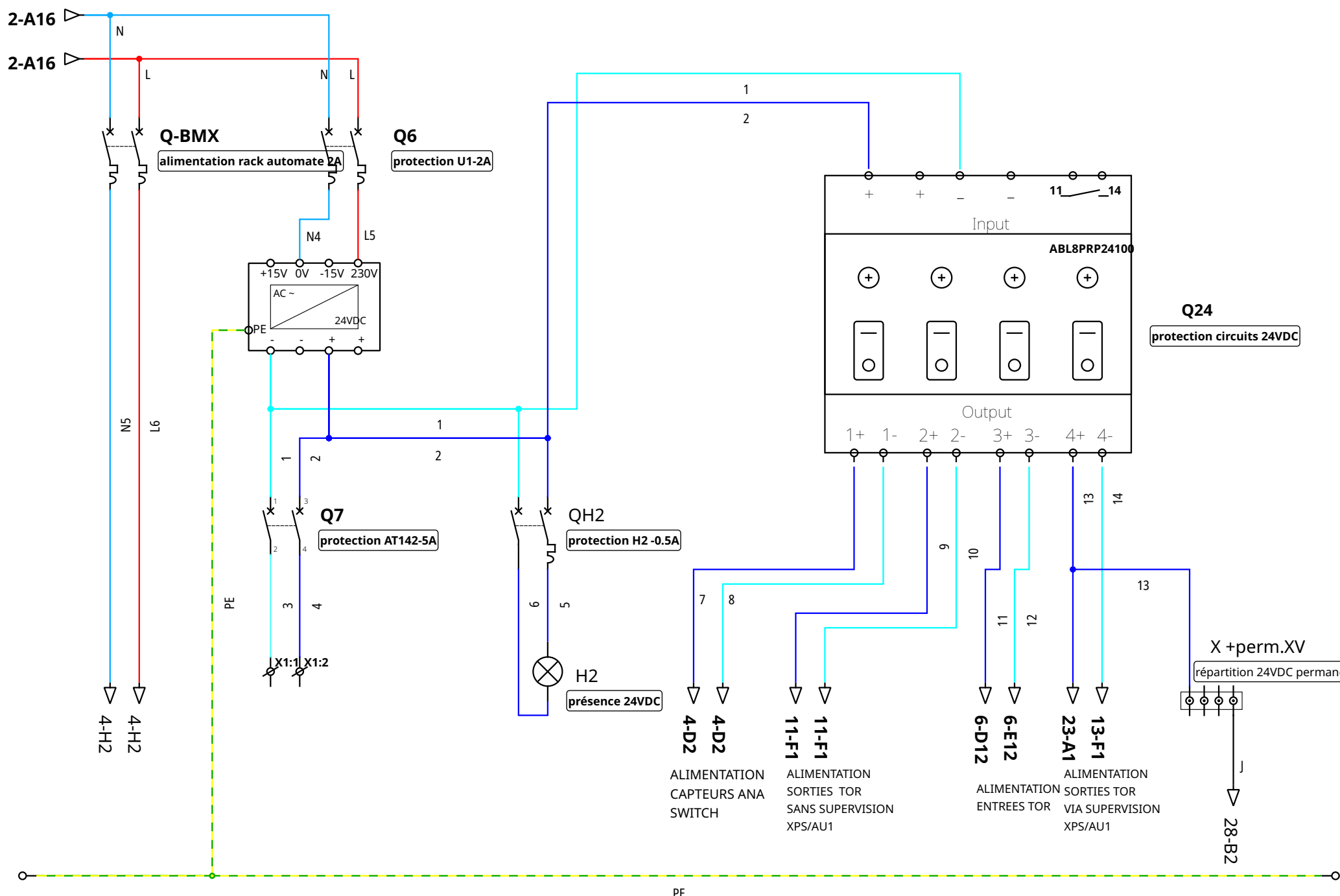

distribution puissance 400Vac/240Vac

I0002188751	
osmose 2X9m3/h	Folio : 2
	Folio : 34



			29/07/2019	
0	EMIS		DESSINE	LC
REV	MODIFICATION	29/07/2019	APROUV	SP



Distribution 24VDC

I0002188751	
osmose 2X9m3/h	Folio : 3
	Folio : 34

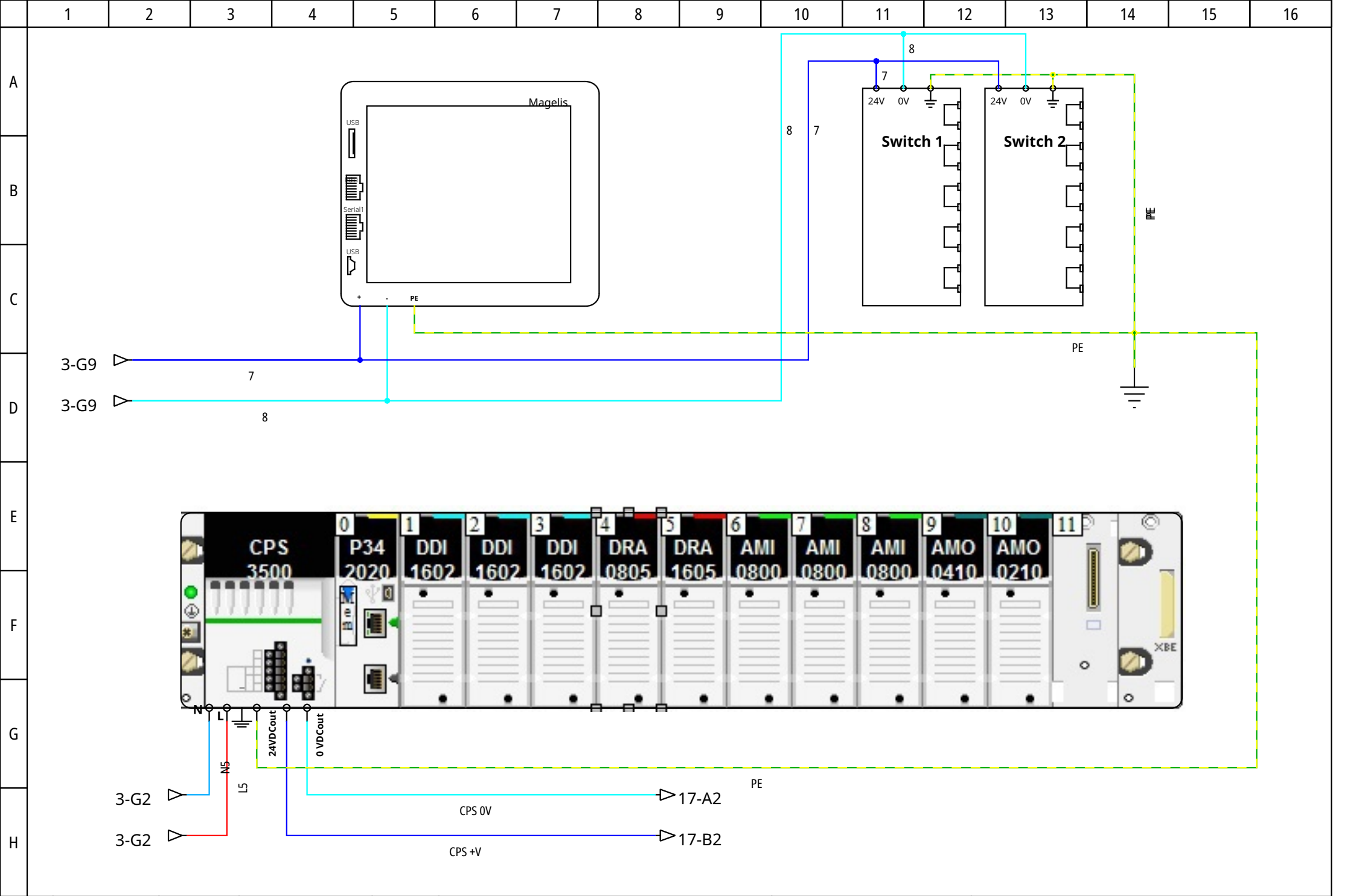

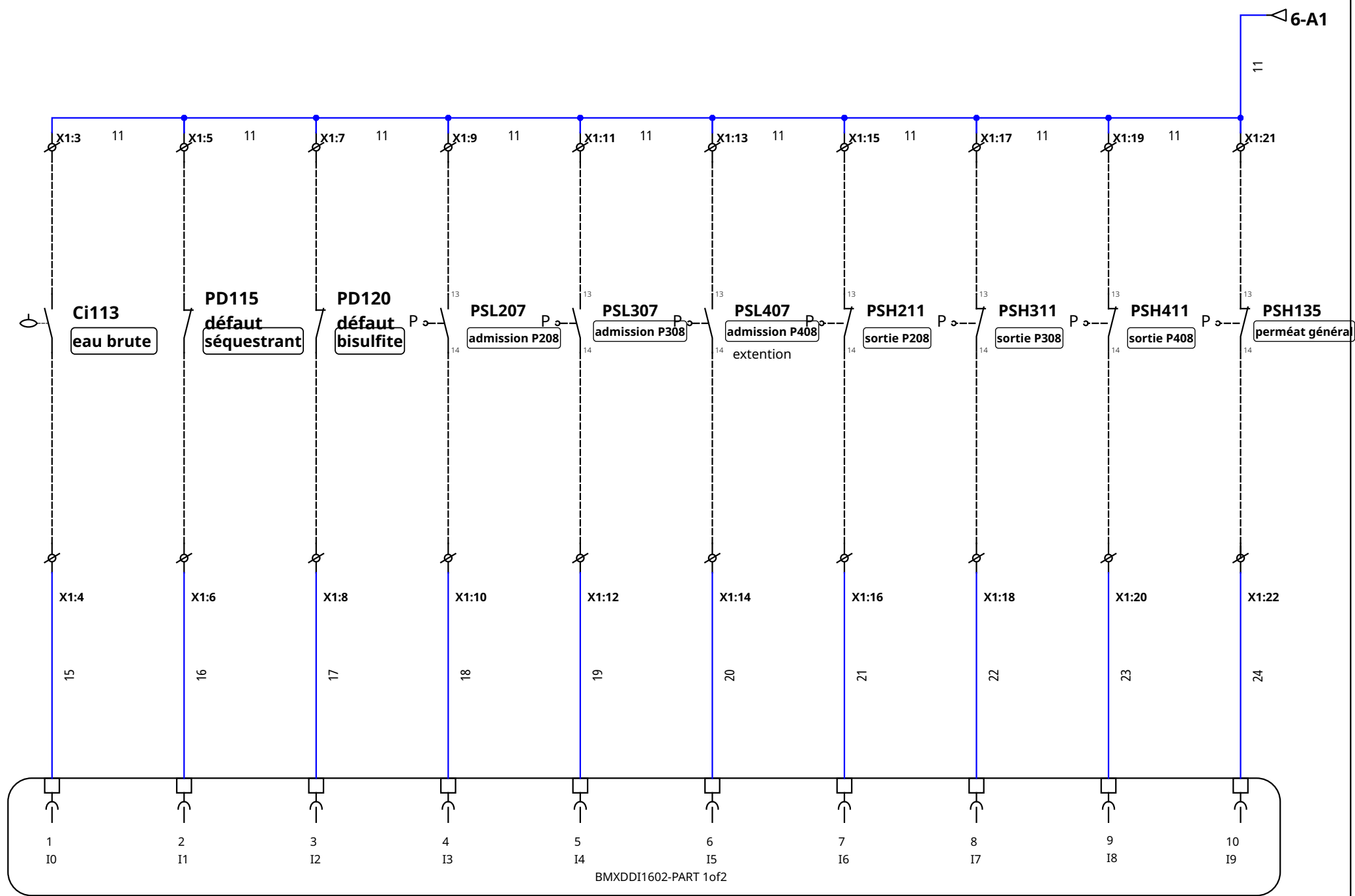

BMXDDI1602-PART 1of2

			29/07/2019	
0	EMIS		DESSINE	LC
REV	MODIFICATION	29/07/2019	APROUV	SP



carte 1 partie 1-entrées TOR

I0002188751	
osmose 2X9m3/h	Folio : 5
	Folio : 34

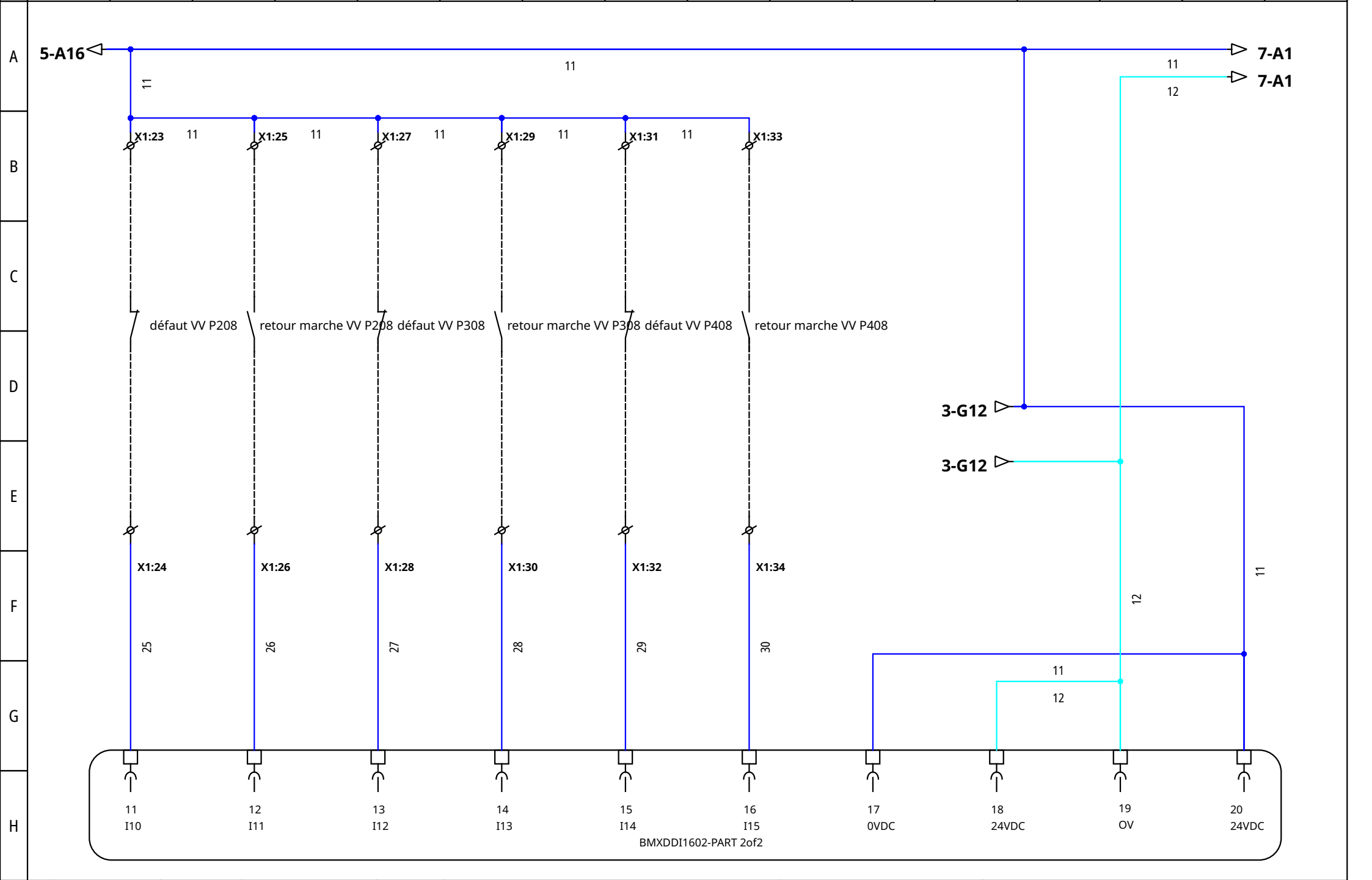

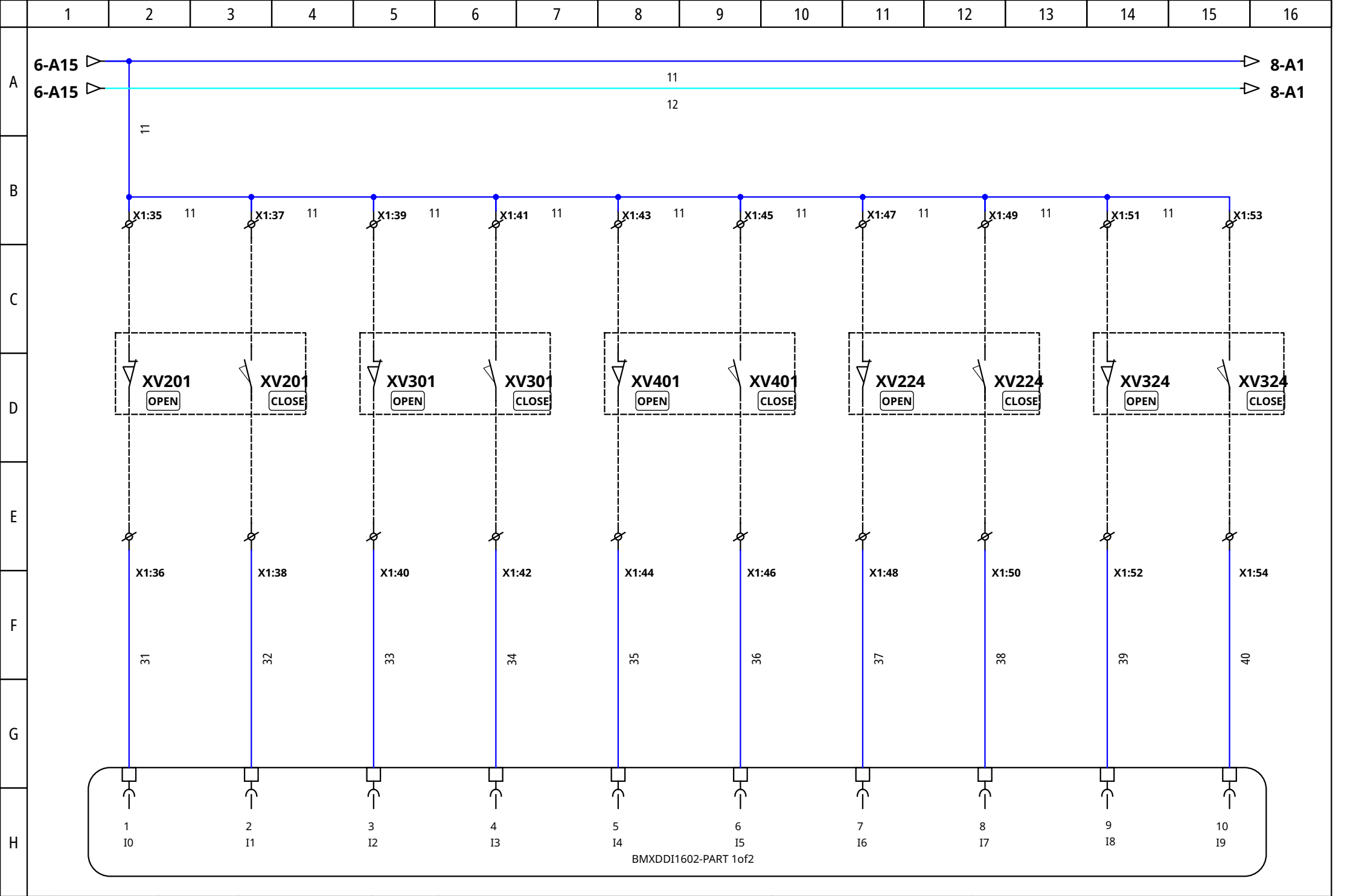

BMXDDI1602-PART 1of2

			29/07/2019	
0	EMIS		DESSINE	LC
REV	MODIFICATION	29/07/2019	APROUV	SP



carte 2 partie 1-entrées TOR

I0002188751	
osmose 2X9m3/h	Folio : 7
	Folio : 34

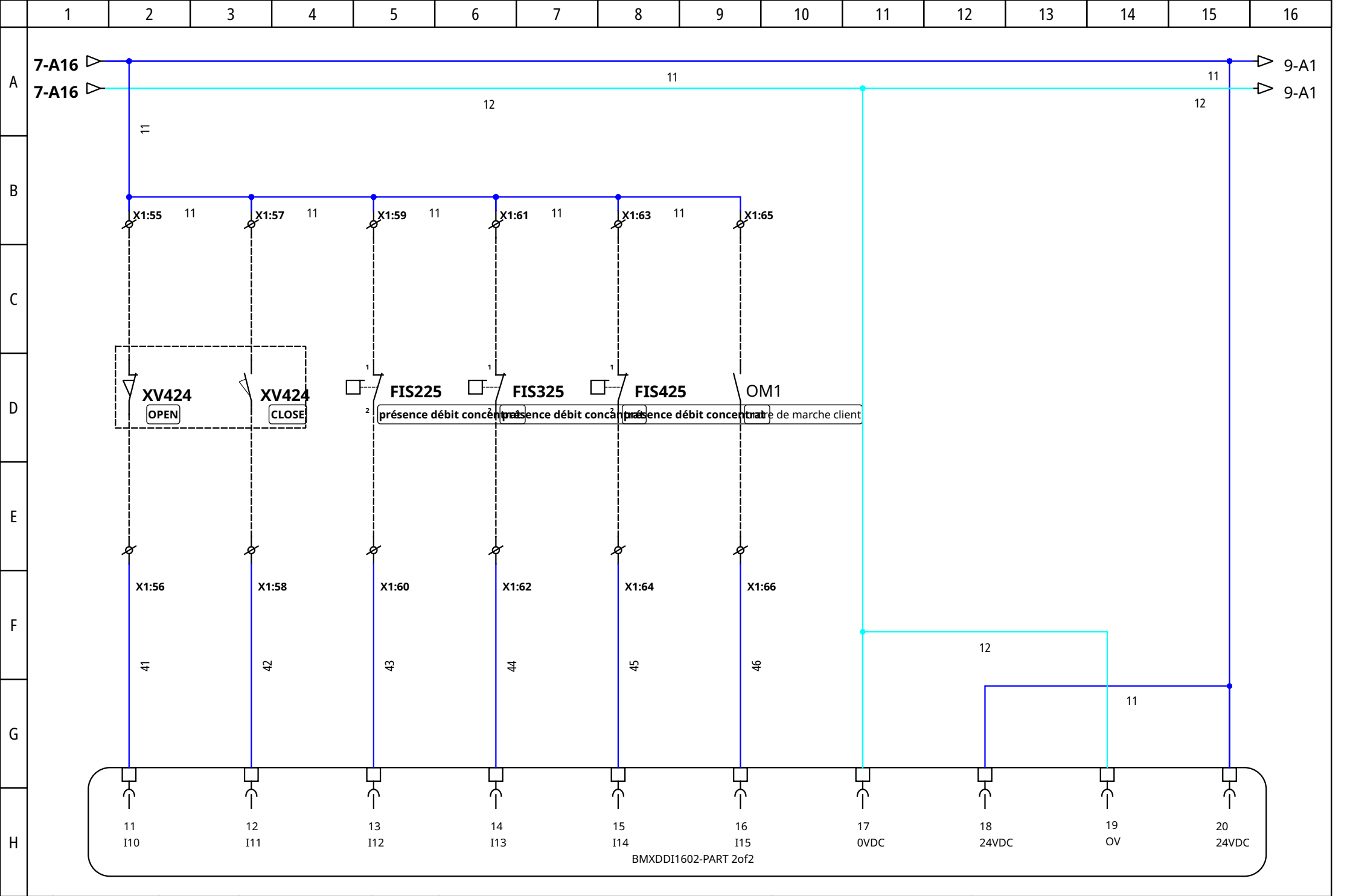

		29/07/2019				I0002188751	
		DESSINE		LC		osmose 2X9m3/h	
0	EMIS	CONTROL		LC		Folio : 8	
REV	MODIFICATION	29/07/2019	APROUV	SP		Folio : 34	



carte 2 partie 2-entrées TOR

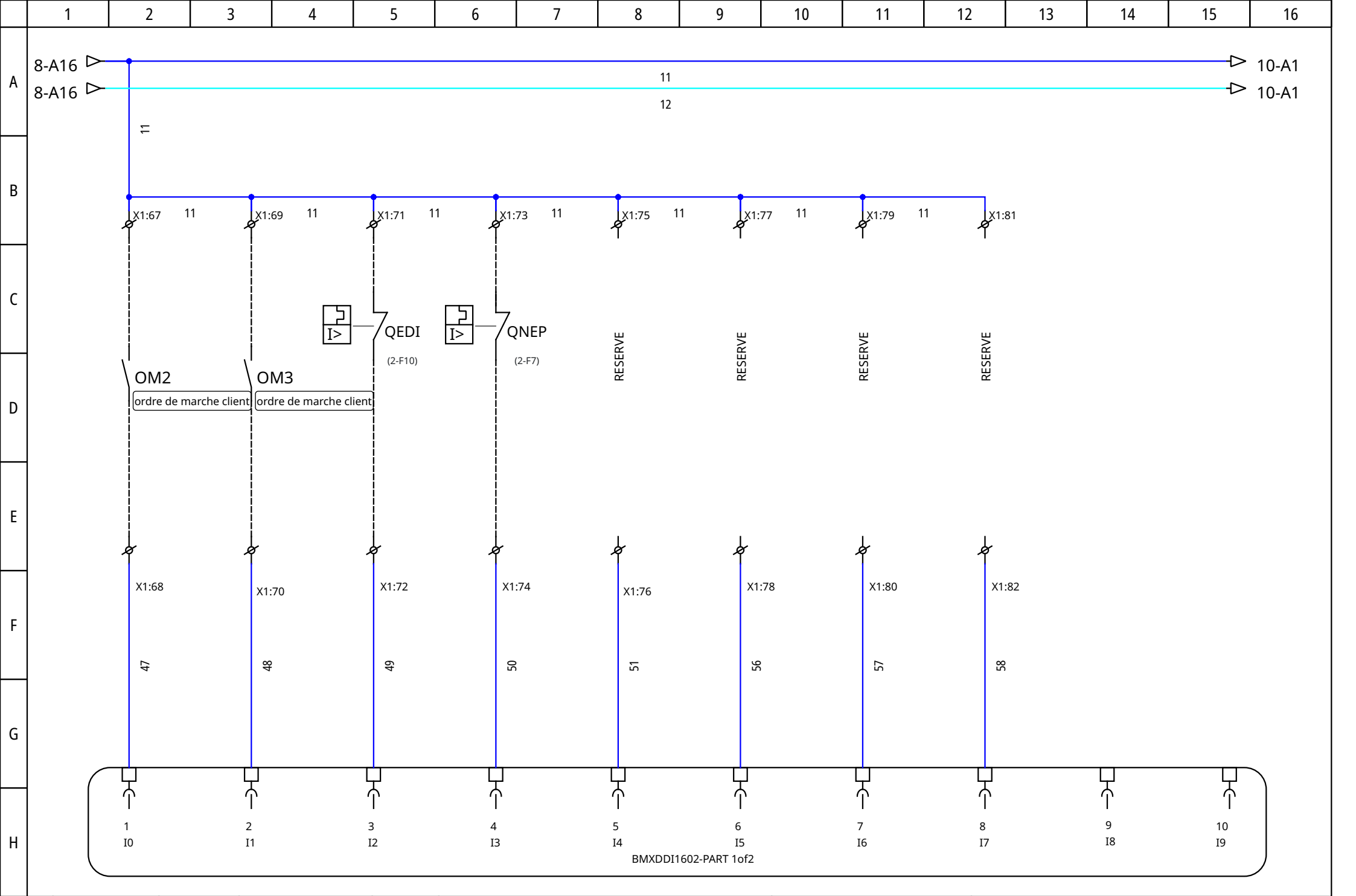

		29/07/2019				I0002188751	
		DESSINE		LC		carte 3 partie 1-entrées TOR	
0	EMIS	CONTROL		LC		osmose 2X9m3/h	
REV	MODIFICATION	29/07/2019	APROUV	SP		Folio : 9	
						Folio : 34	



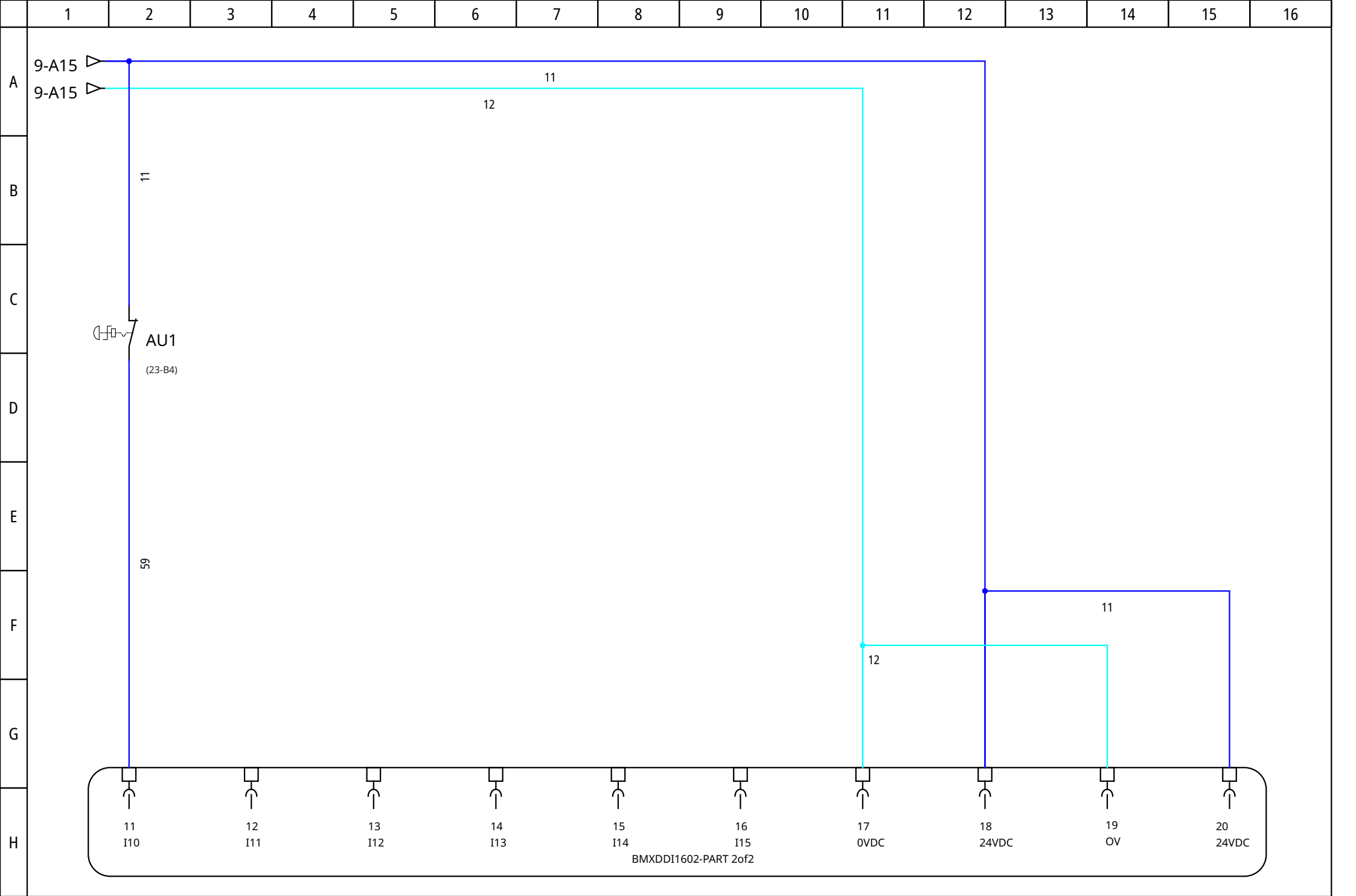

			29/07/2019			carte 3 partie 2-entrées TOR	I0002188751	
0	EMIS		DESSINE	LC			osmose 2X9m3/h	Folio : 10
REV	MODIFICATION	29/07/2019	APROUV	SP		Folio : 34		

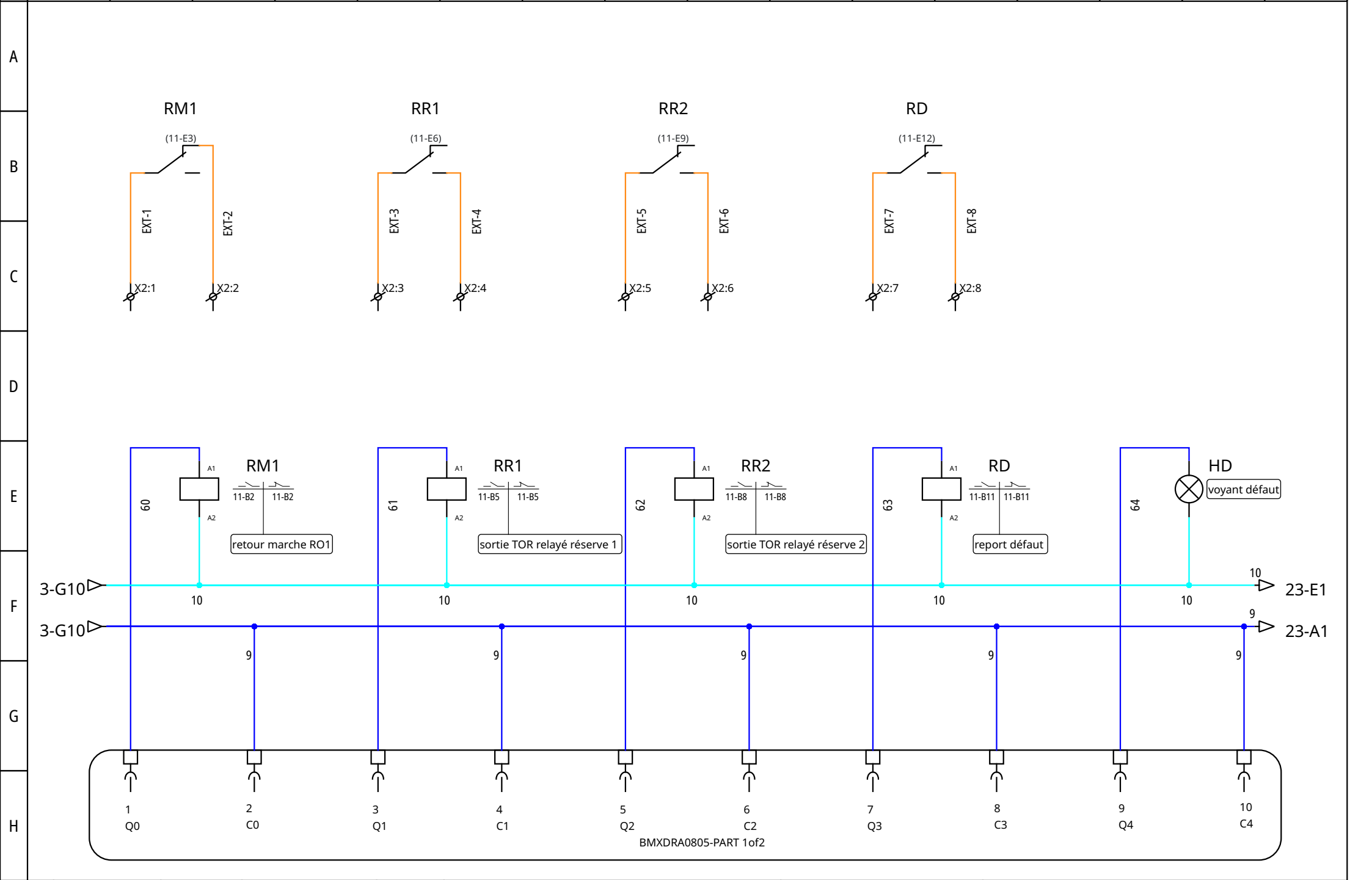

1 2 3 4 5 6 7 8 9 10 11 12 13 14 15 16

A
B
C
D
E
F
G
H

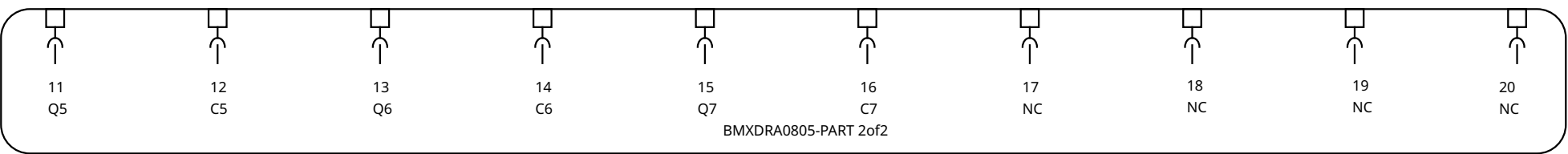

BMXDRA0805-PART 2of2

			29/07/2019	
0	EMIS		DESSINE	LC
REV	MODIFICATION	29/07/2019	APROUV	SP



carte 4 partie 2- sorties TOR

I0002188751	
osmose 2X9m3/h	Folio : 12
	Folio : 34

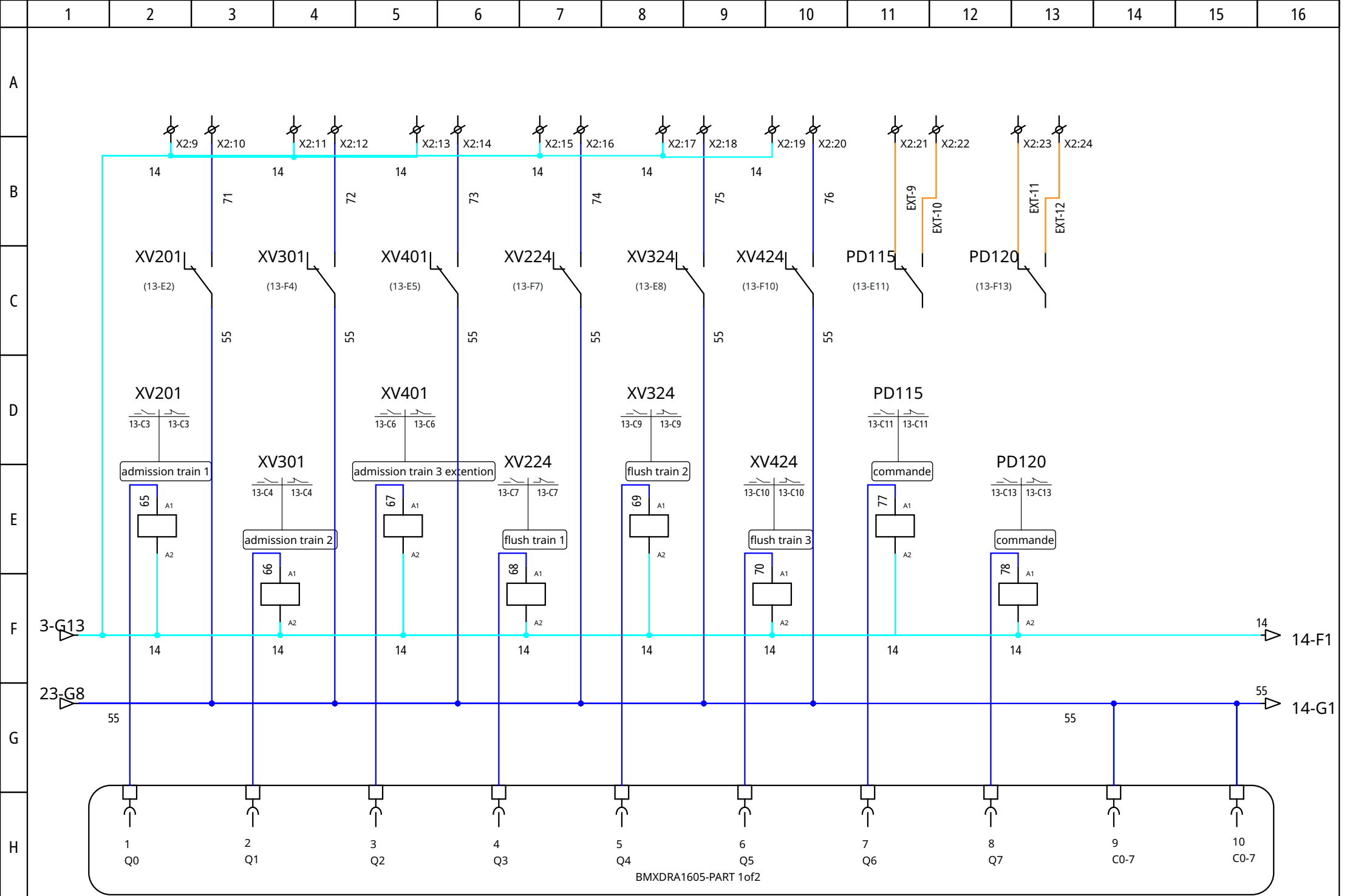

		29/07/2019						I0002188751	
		DESSINE		LC				carte 5 partie 1-sorties TOR	
0	EMIS	CONTROL		LC				osmose 2X9m3/h	
REV	MODIFICATION	29/07/2019	APROUV		SP				Folio : 13
									Folio : 34



BMXDRA1605-PART 1of2

A
B
C
D
E
F
G
H

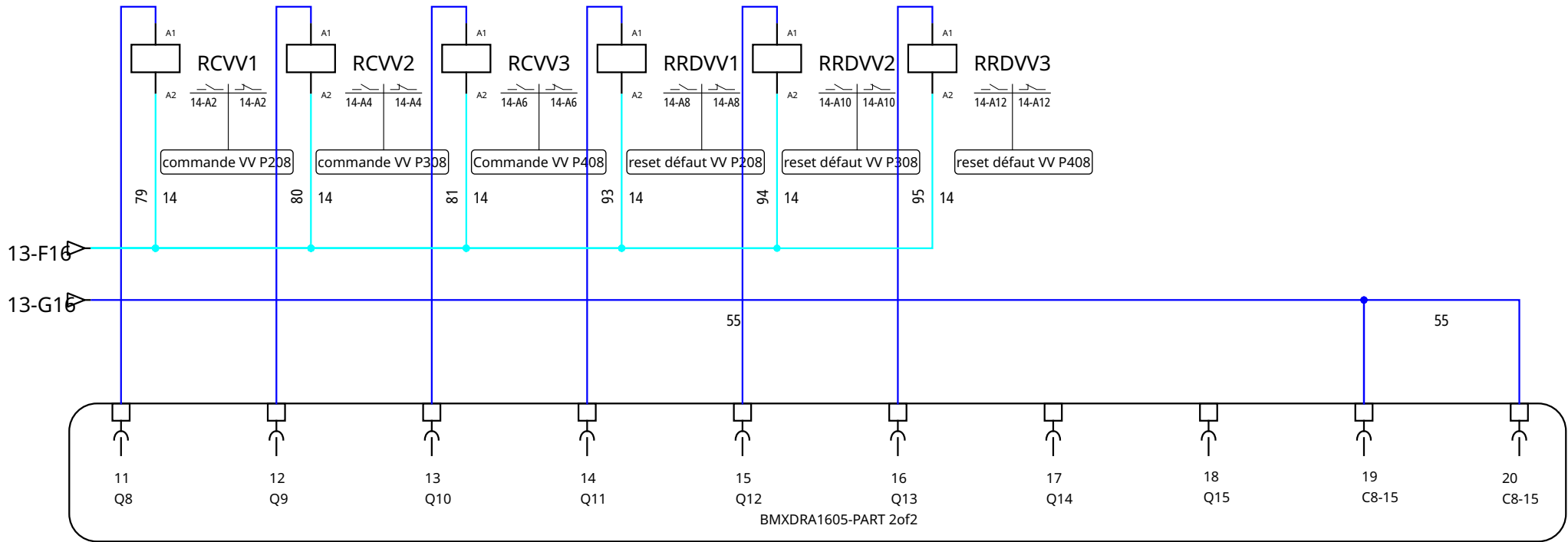
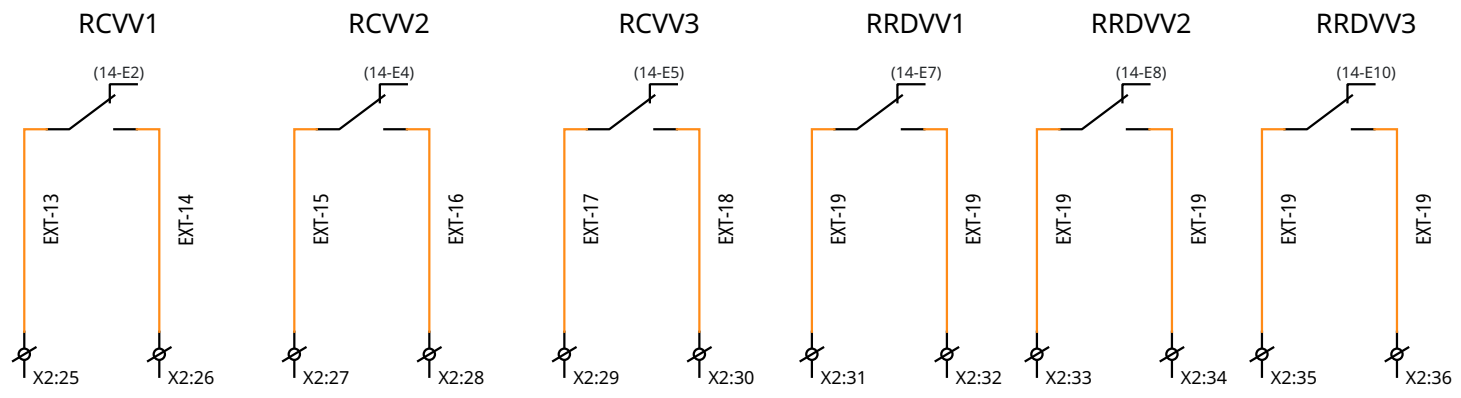

BMXDRA1605-PART 2of2

			29/07/2019	
0	EMIS		DESSINE	LC
REV	MODIFICATION	29/07/2019	APROUV	SP



carte 5 partie 2-sorties TOR

I0002188751	
osmose 2X9m3/h	Folio : 14
	Folio : 34

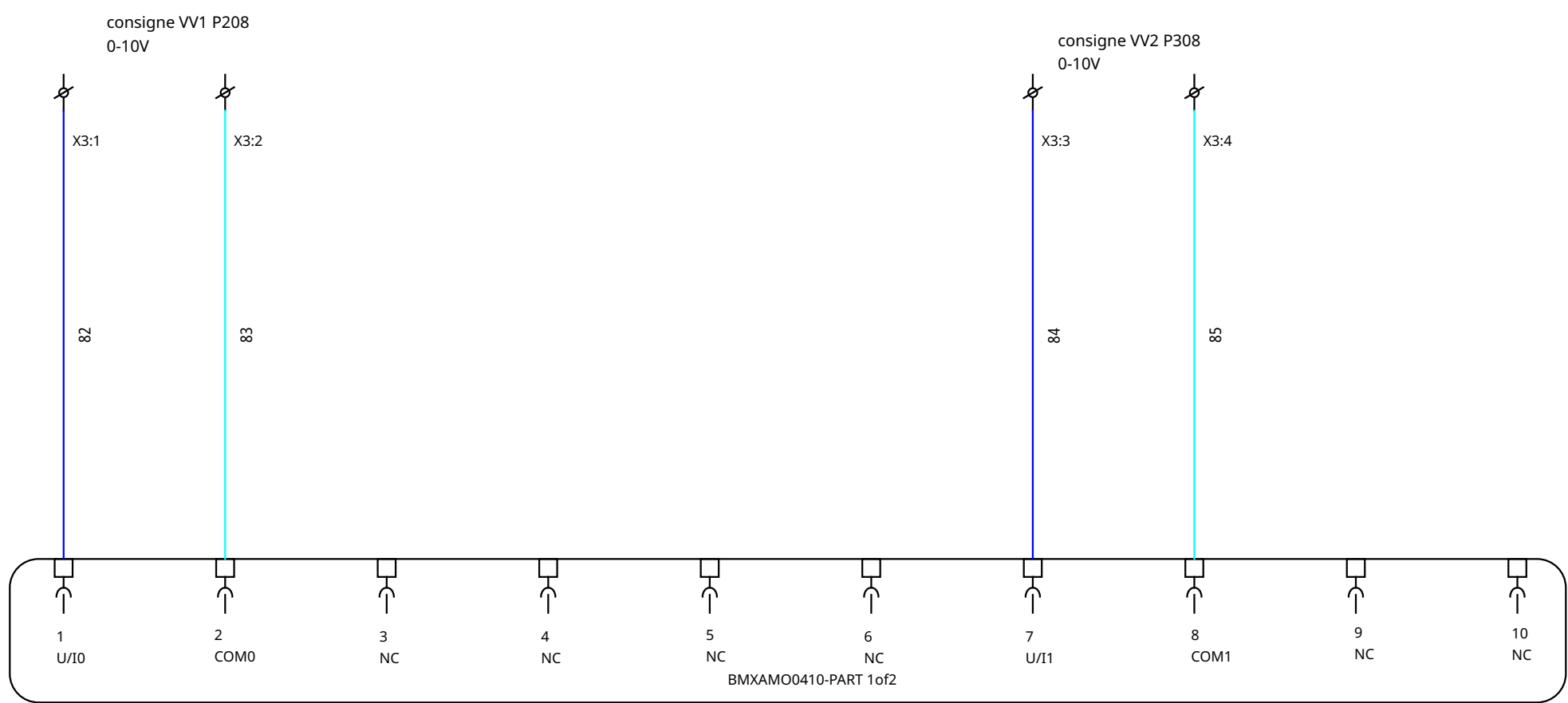

			29/07/2019	
0	EMIS		DESSINE	LC
REV	MODIFICATION	29/07/2019	APROUV	SP



carte 6 partie1-sortie ANA

I0002188751	
osmose 2X9m3/h	Folio : 15
	Folio : 34

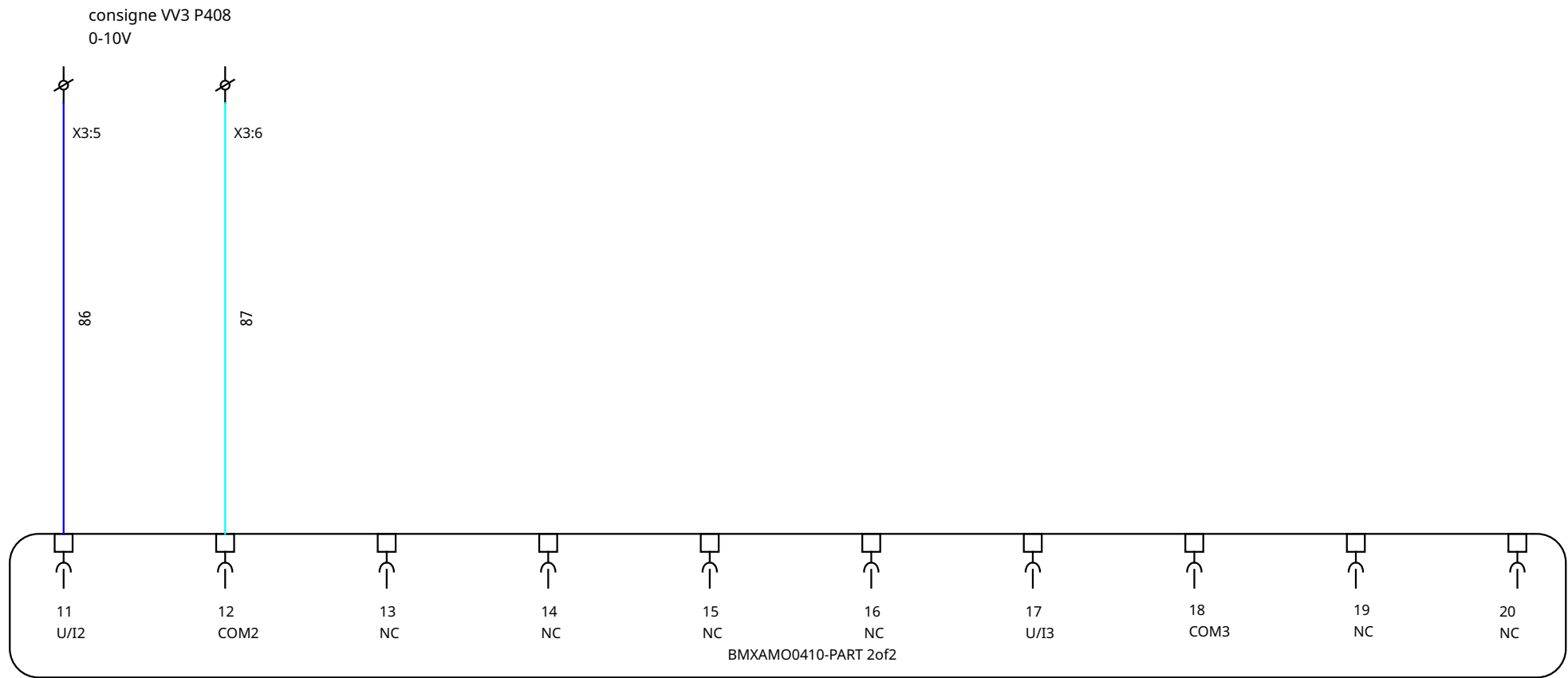

			29/07/2019	
0	EMIS		DESSINE	LC
REV	MODIFICATION	29/07/2019	APROUV	SP



carte 6 partie 2-sorties ANA

I0002188751	
osmose 2X9m3/h	Folio : 16
	Folio : 34

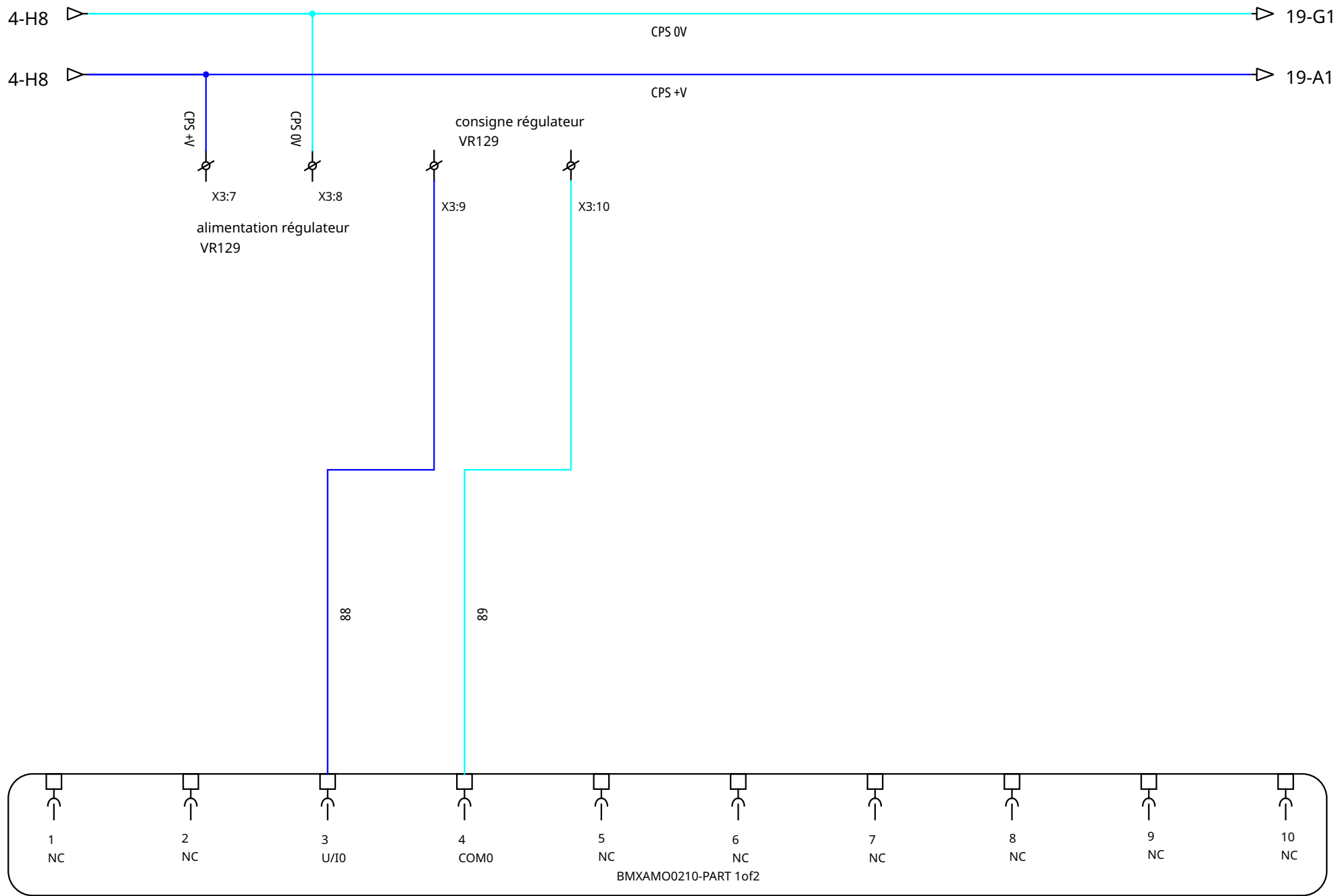

			29/07/2019	
0	EMIS		DESSINE	LC
REV	MODIFICATION	29/07/2019	APROUV	SP



carte 7 partie 1- sorties ANA

I0002188751	
osmose 2X9m3/h	Folio : 17
	Folio : 34

1 2 3 4 5 6 7 8 9 10 11 12 13 14 15 16

A
B
C
D
E
F
G
H

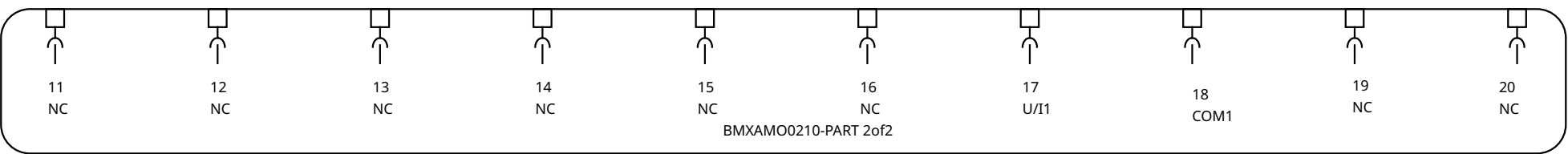

BMXAMO0210-PART 2of2

			29/07/2019	
0	EMIS		DESSINE	LC
REV	MODIFICATION	29/07/2019	APROUV	SP



carte 7 partie 2- sorties ANA

I0002188751	
osmose 2X9m3/h	Folio : 18
	Folio : 34

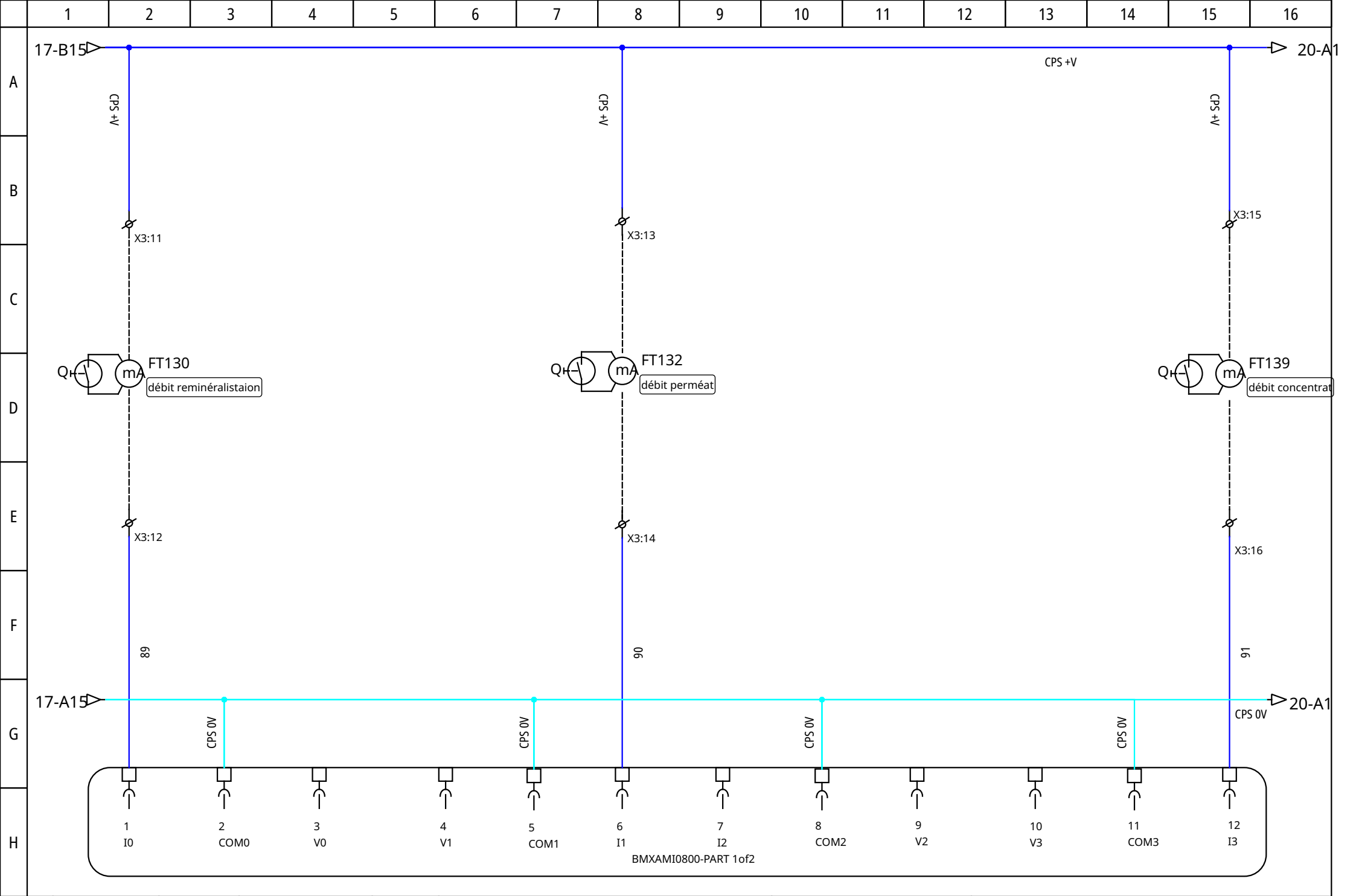

			29/07/2019	
0	EMIS		DESSINE	LC
REV	MODIFICATION	29/07/2019	APROUV	SP



carte 8 partie 1-entrées ANA

I0002188751	
osmose 2X9m3/h	Folio : 19
	Folio : 34

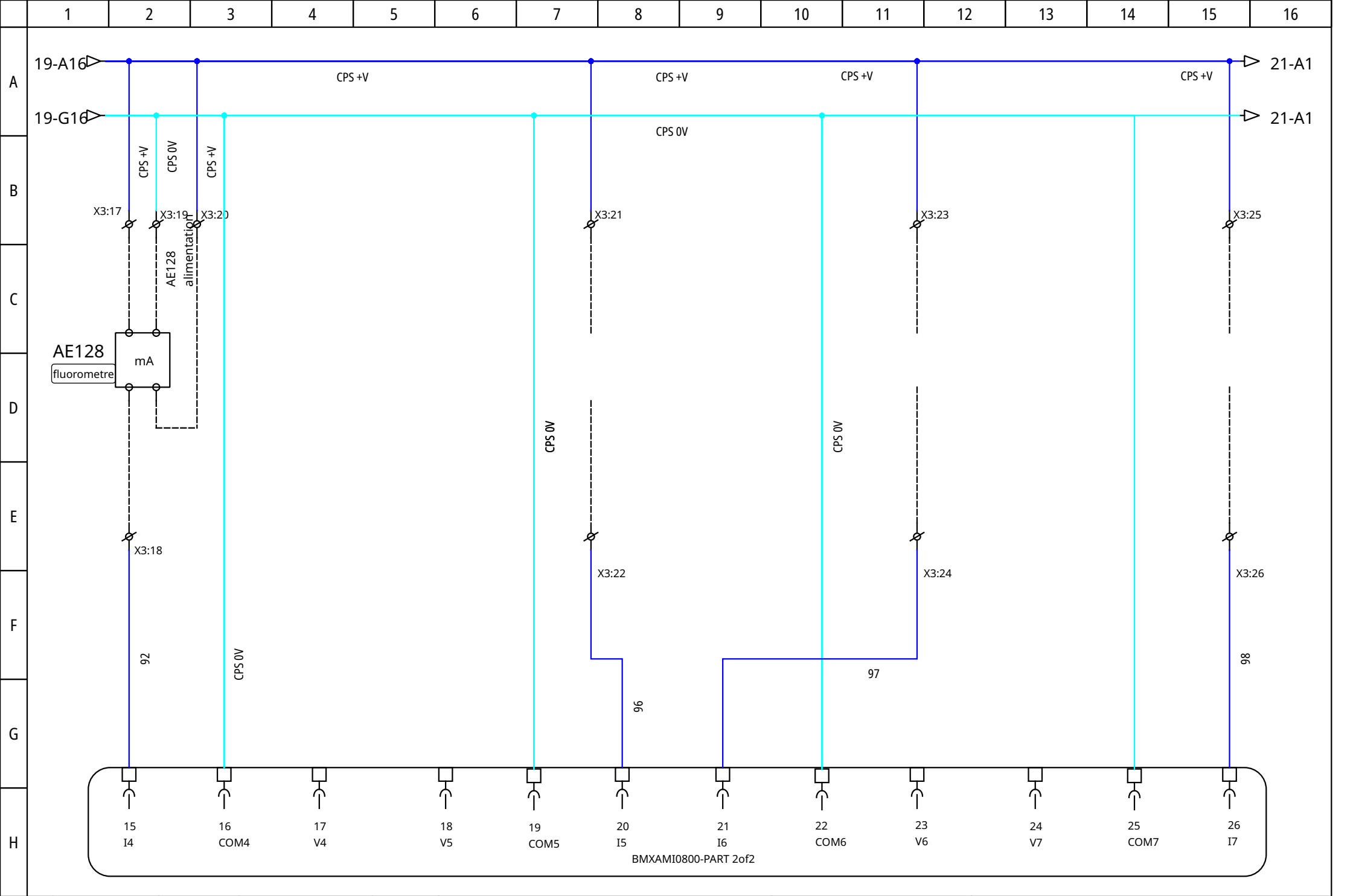

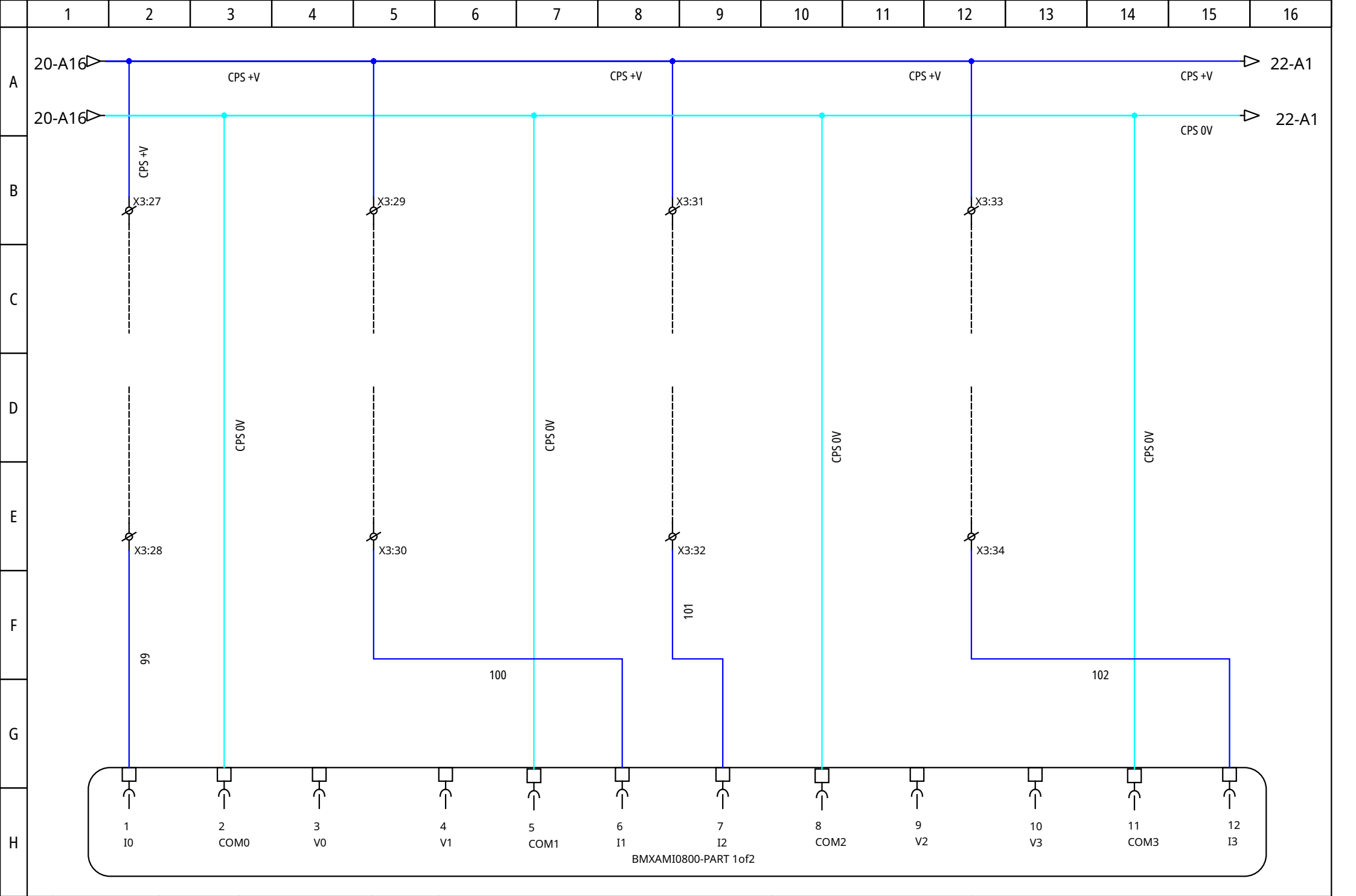

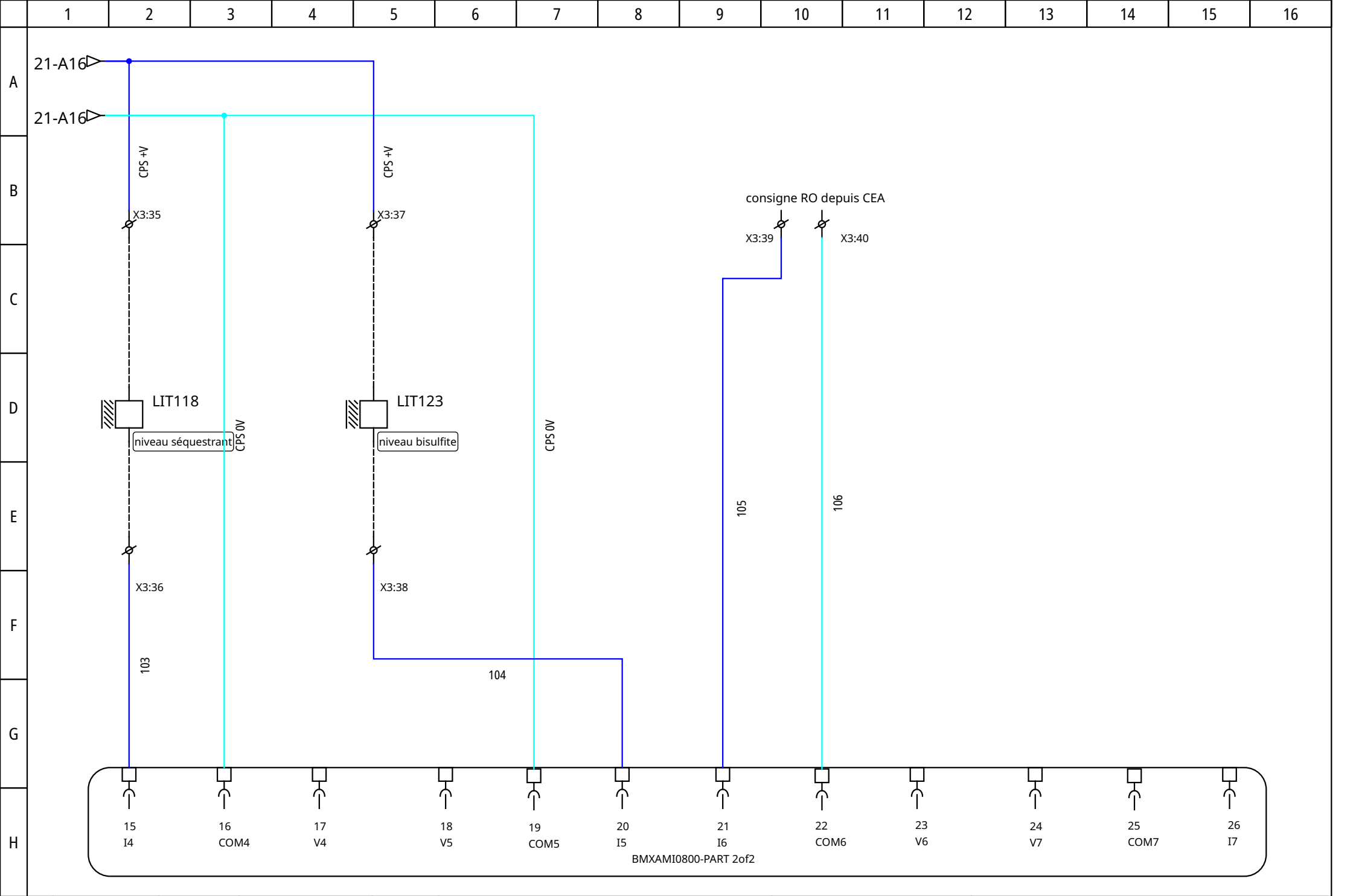

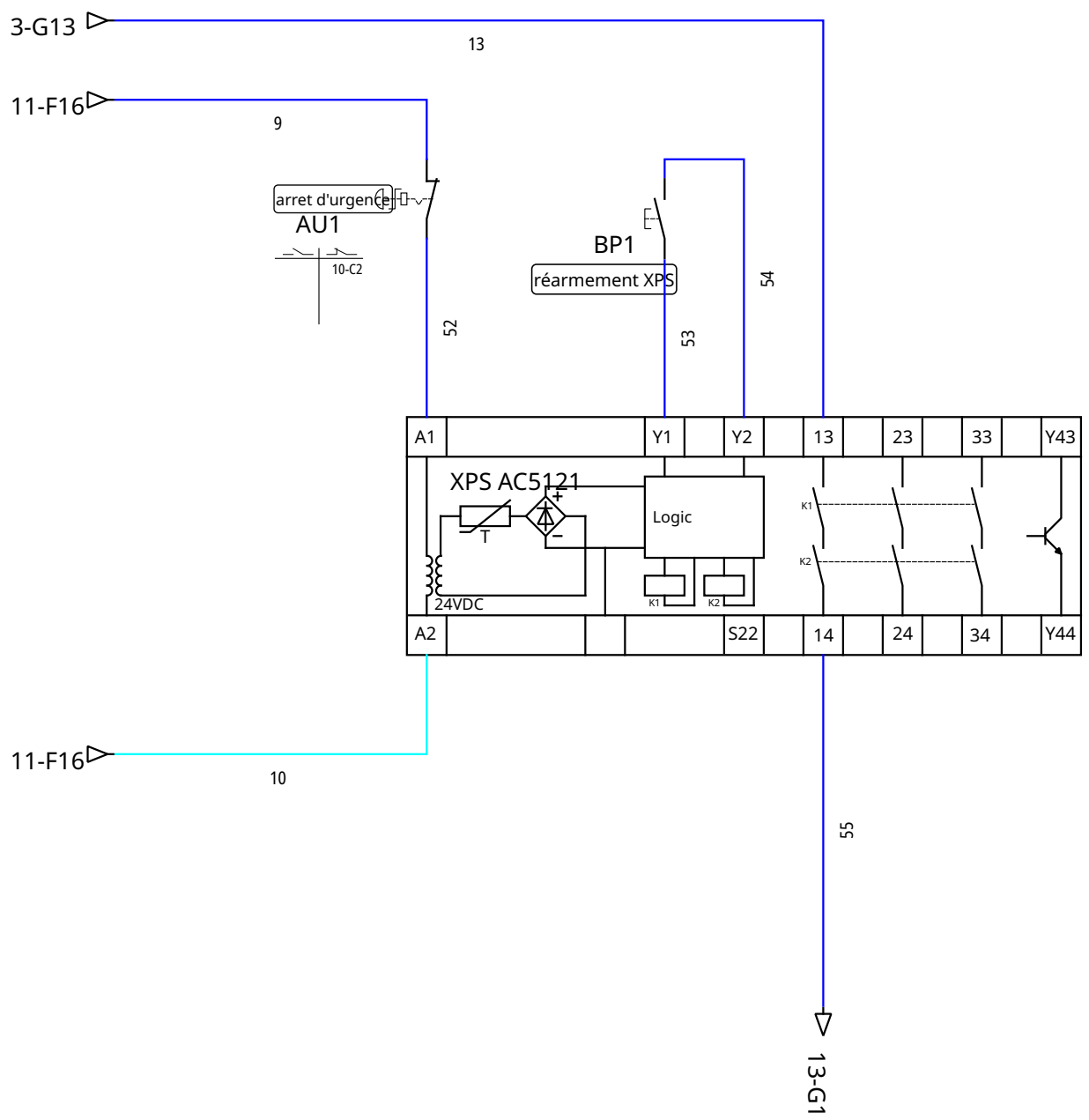

XPS
supervision arrêt d'urgence

			29/07/2019	
0	EMIS		DESSINE	LC
REV	MODIFICATION	29/07/2019	APROUV	SP



gestion arrêt d'urgence

I0002188751	
osmose 2X9m3/h	Folio : 23
	Folio : 34

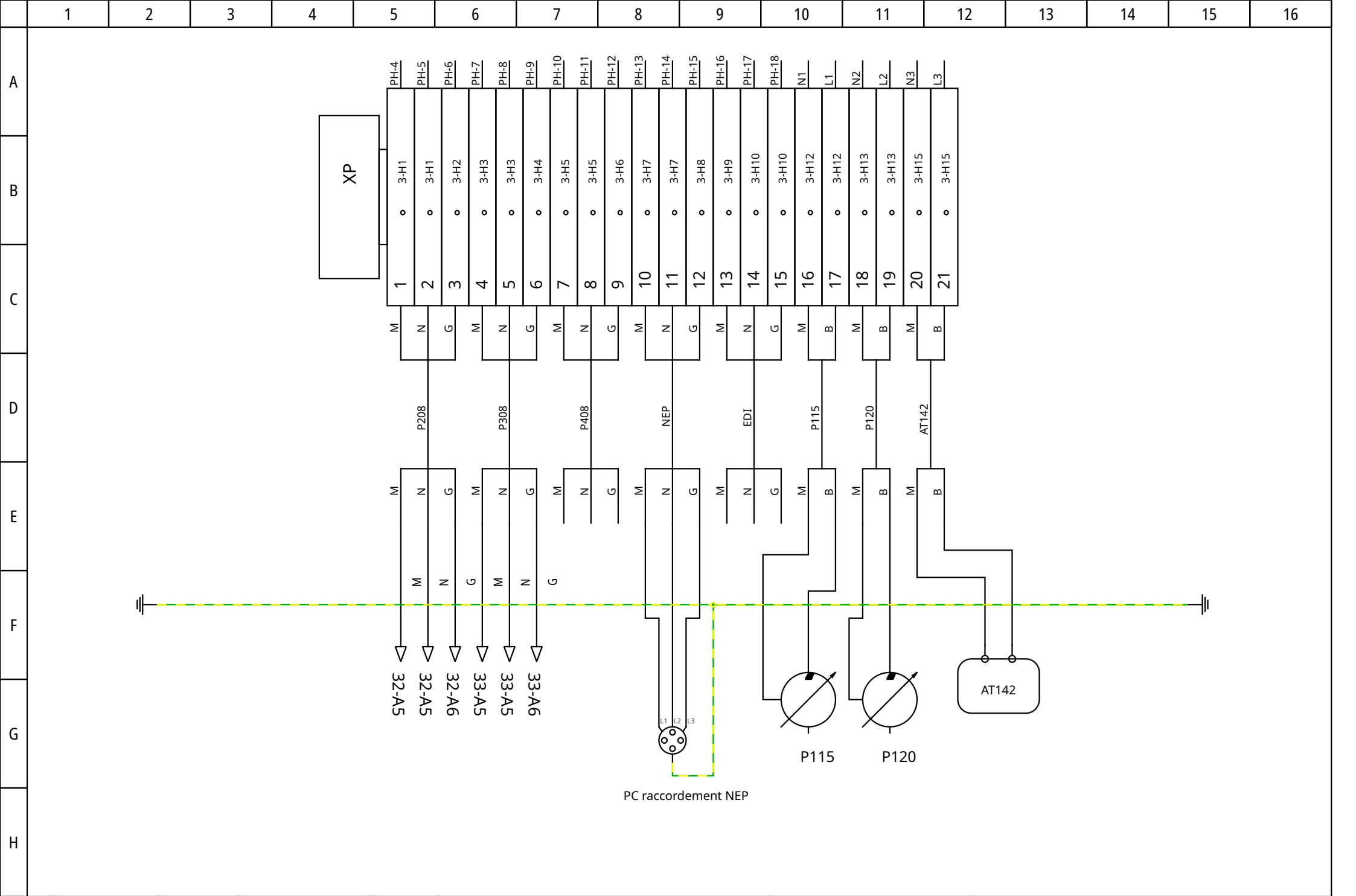

		29/07/2019						I0002188751	
		DESSINE		LC				bornier XP	
0		EMIS		CONTROL		LC		osmose 2X9m3/h	
REV		MODIFICATION		APROUV		SP		Folio : 24	
		29/07/2019						Folio : 34	



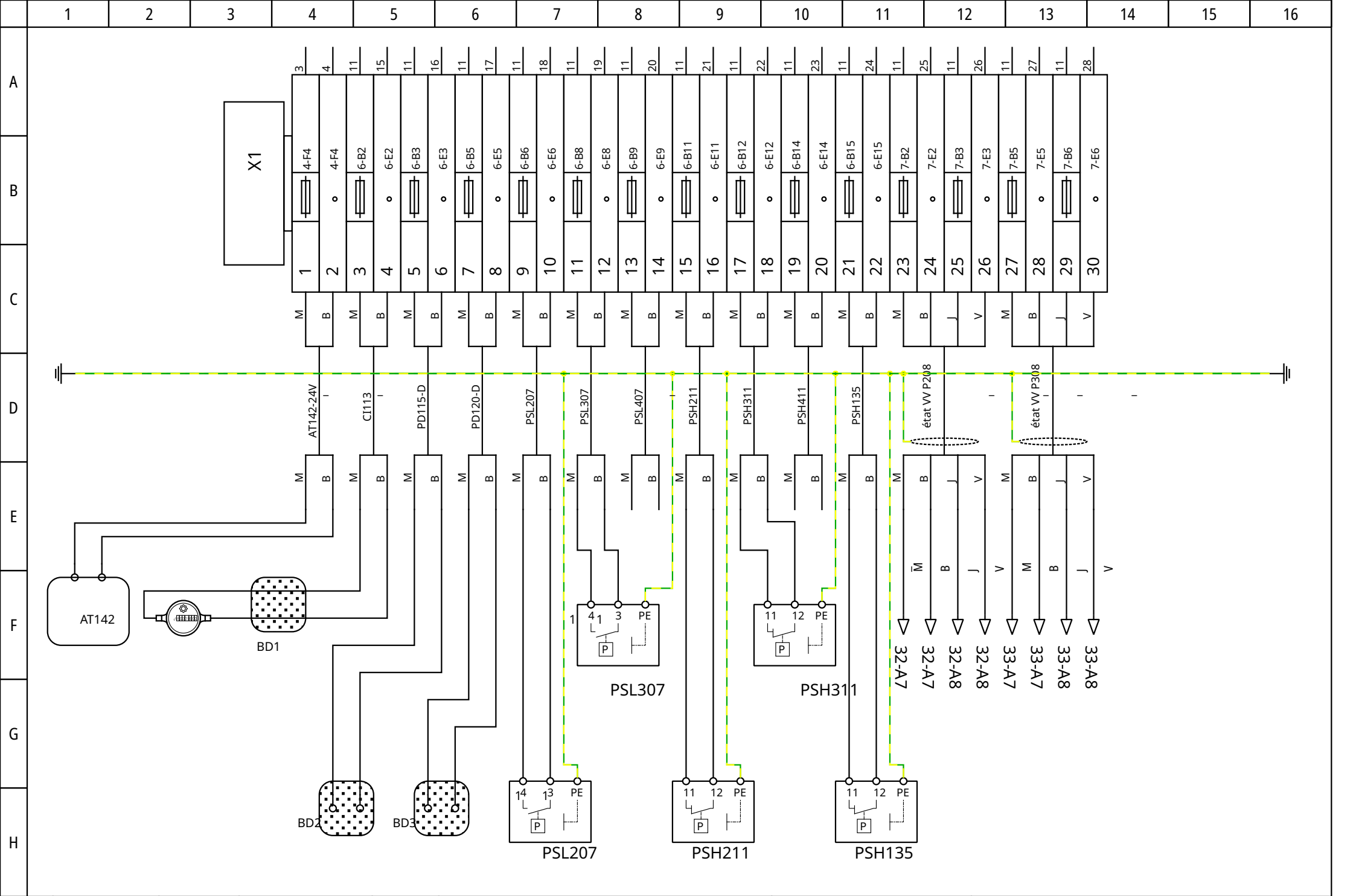

		29/07/2019						I0002188751		
0	EMIS		DESSINE	LC					osmose 2X9m3/h	
REV	MODIFICATION	29/07/2019	APROUV	SP	bornier X1				Folio : 25	
									Folio : 34	



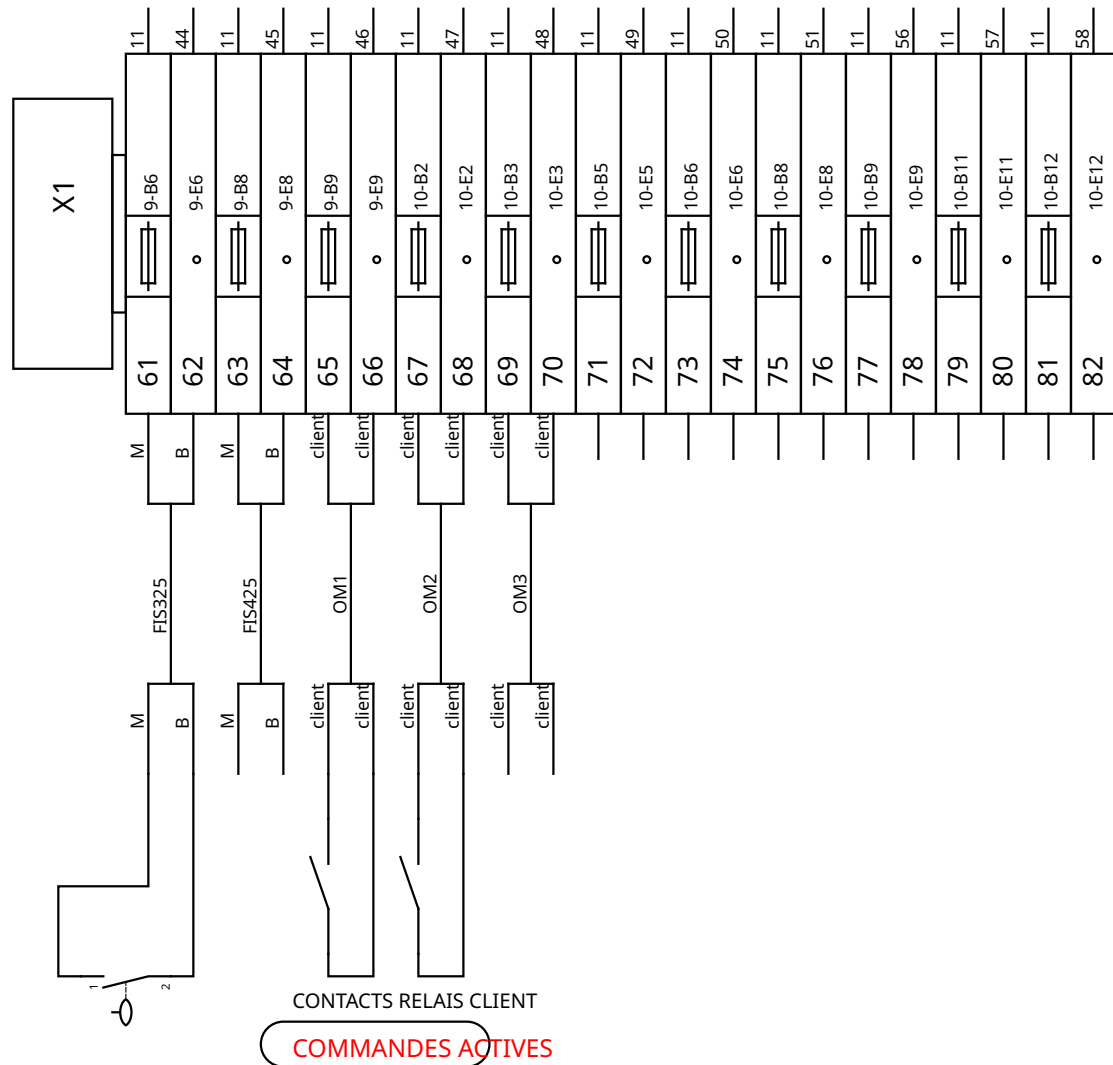

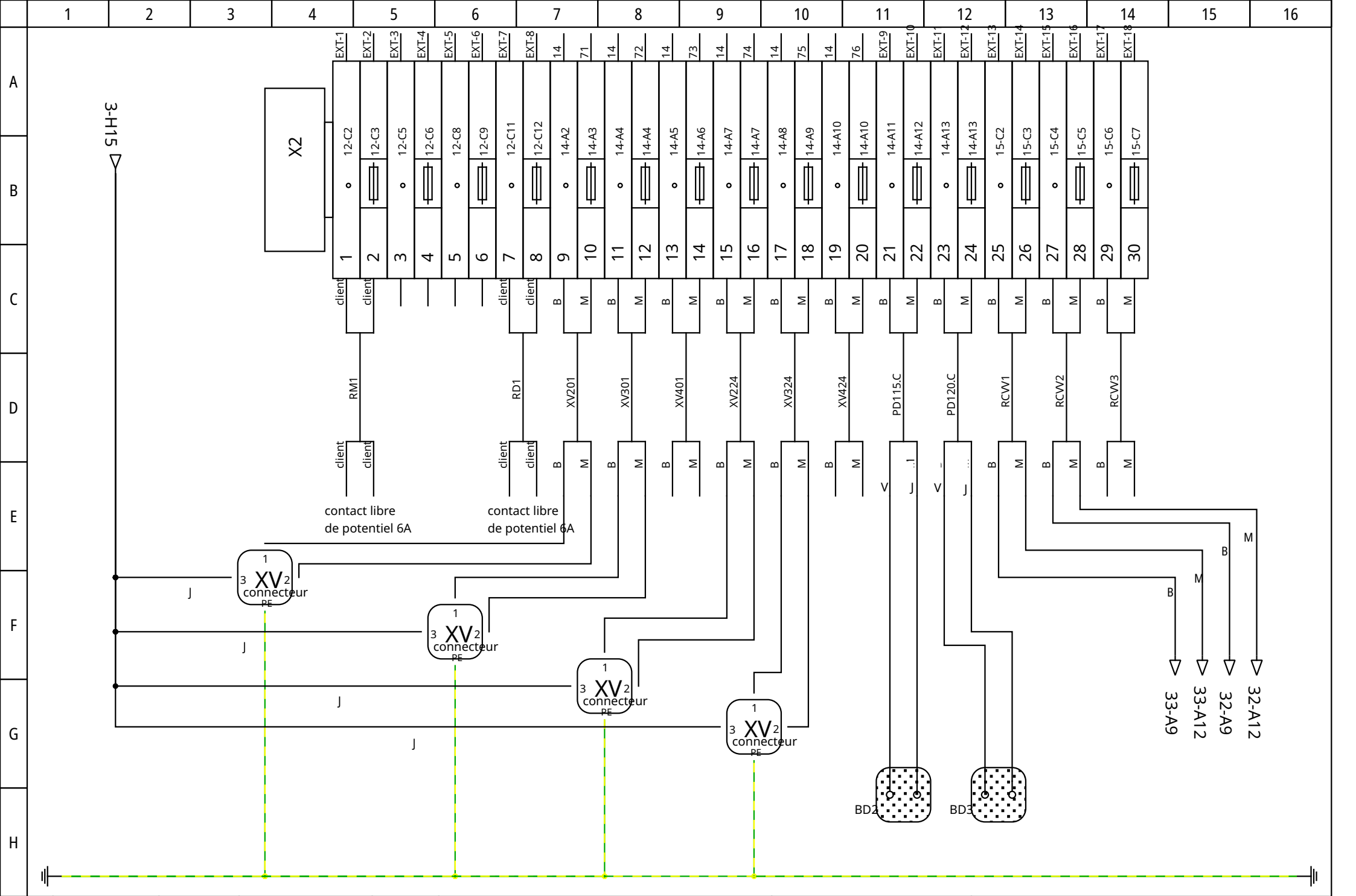

		29/07/2019				bornier X2		I0002188751			
0		DESSINE								LC	
REV		MODIFICATION								SP	
		29/07/2019		APROUV		osmose 2X9m3/h		Folio : 28			
								Folio : 34			

A
B
C
D
E
F
G
H

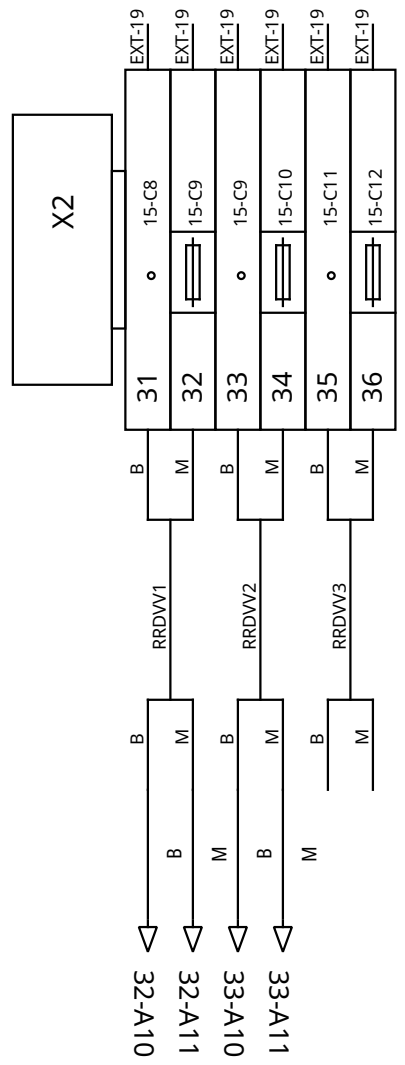

			29/07/2019	
0	EMIS		DESSINE	LC
REV	MODIFICATION	29/07/2019	APROUV	SP



bornier X2

I0002188751	
osmose 2X9m3/h	Folio : 29
	Folio : 34

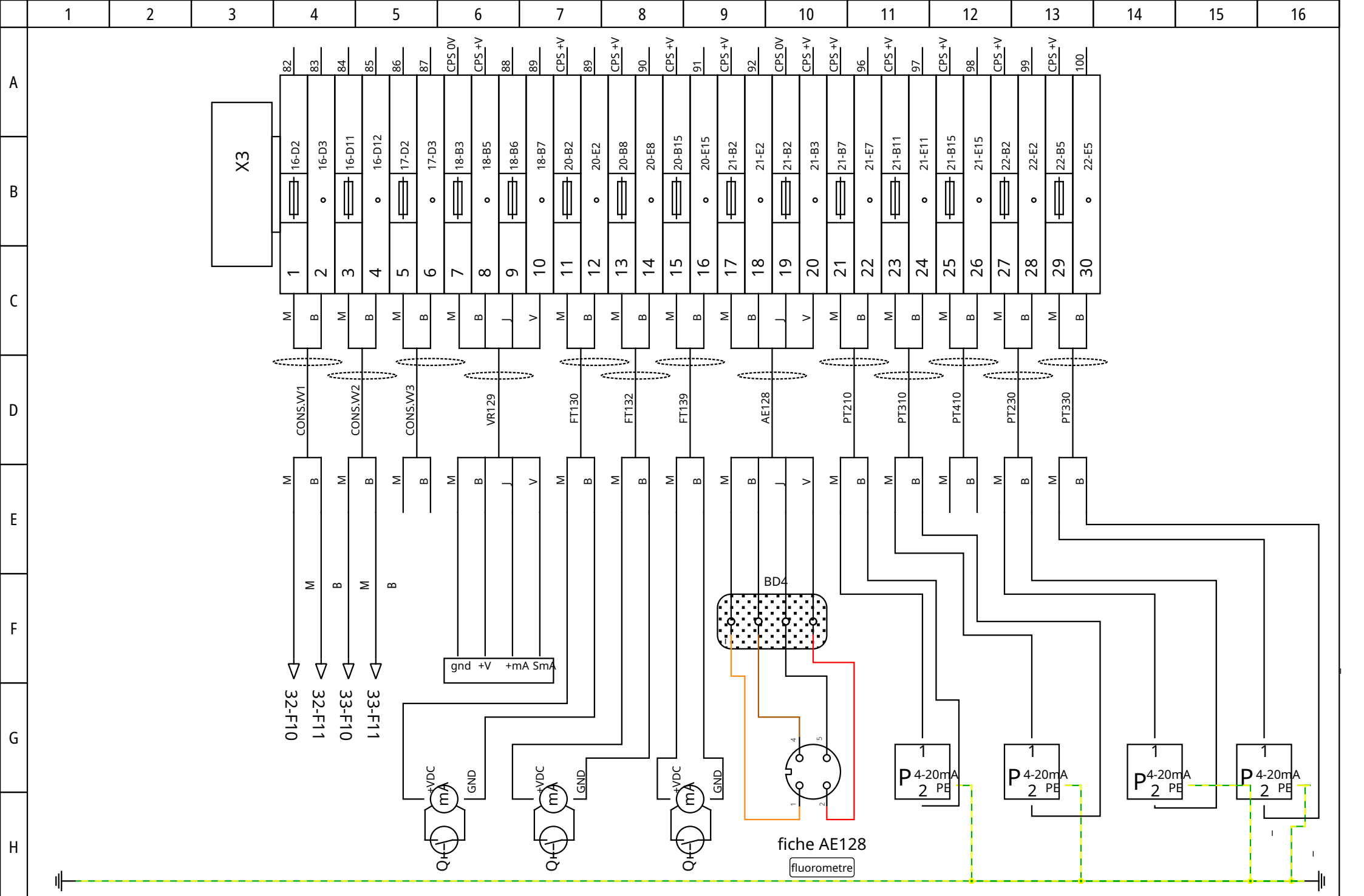

		29/07/2019				bornier X3		I0002188751		
0	EMIS	DESSINE				LC		osmose 2X9m3/h		Folio : 30
REV	MODIFICATION	29/07/2019	APROUV			SP				Folio : 34

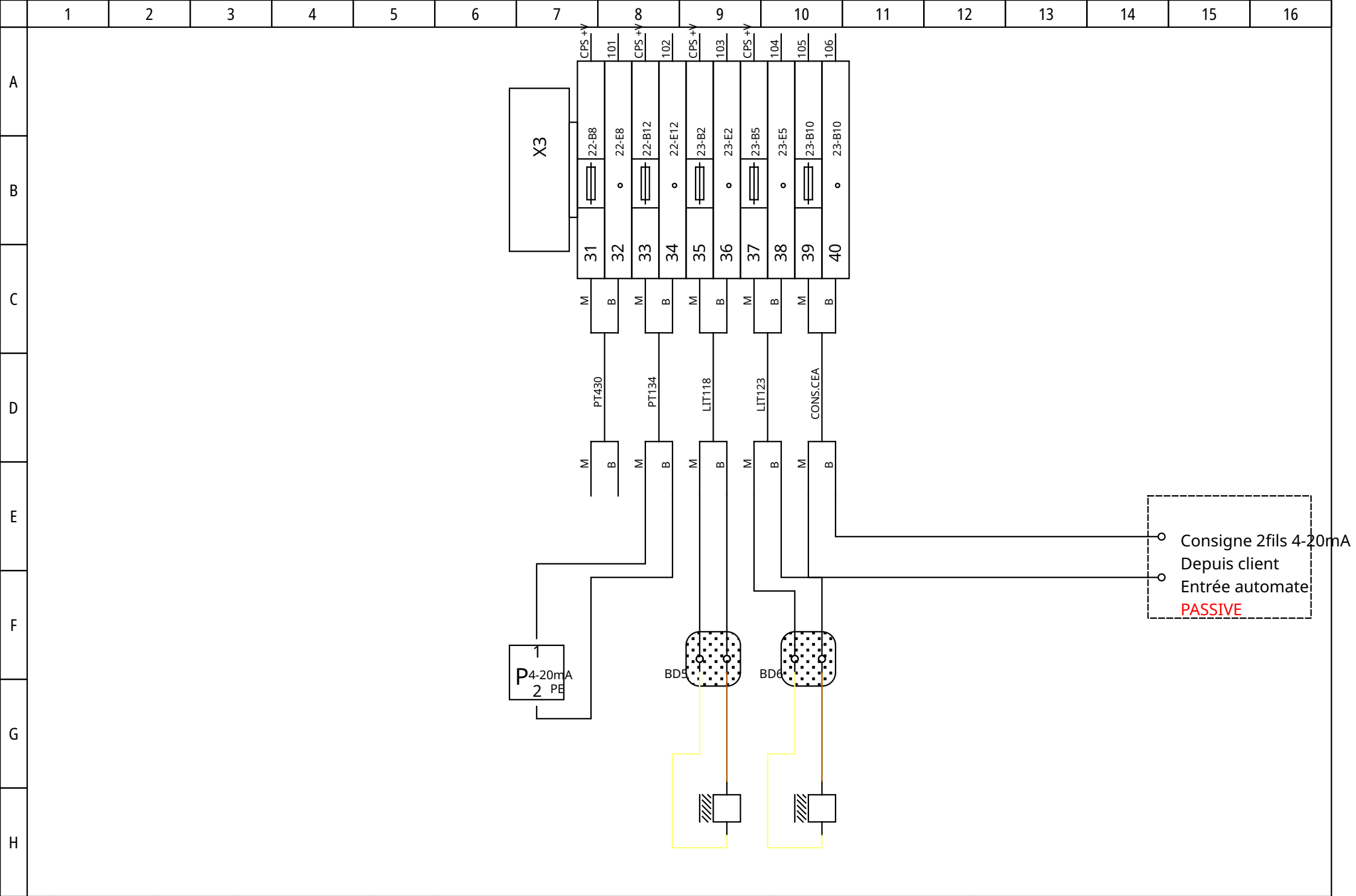

		29/07/2019				I0002188751	
		DESSINE		LC			
0	EMIS	CONTROL		LC			
REV	MODIFICATION	29/07/2019	APROUV	SP		osmose 2X9m3/h	
						bornier X3	
						Folio : 31	
						Folio : 34	



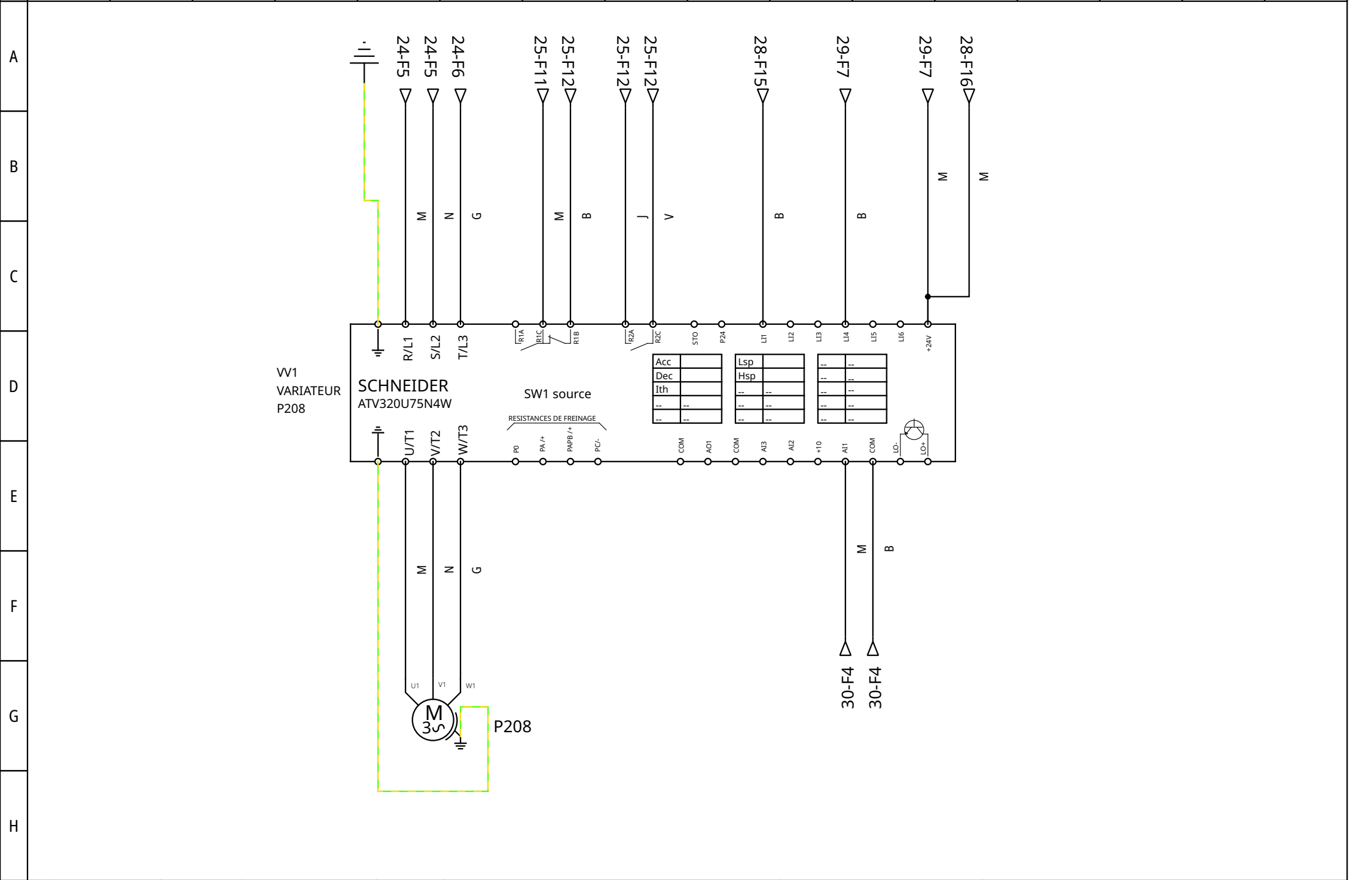

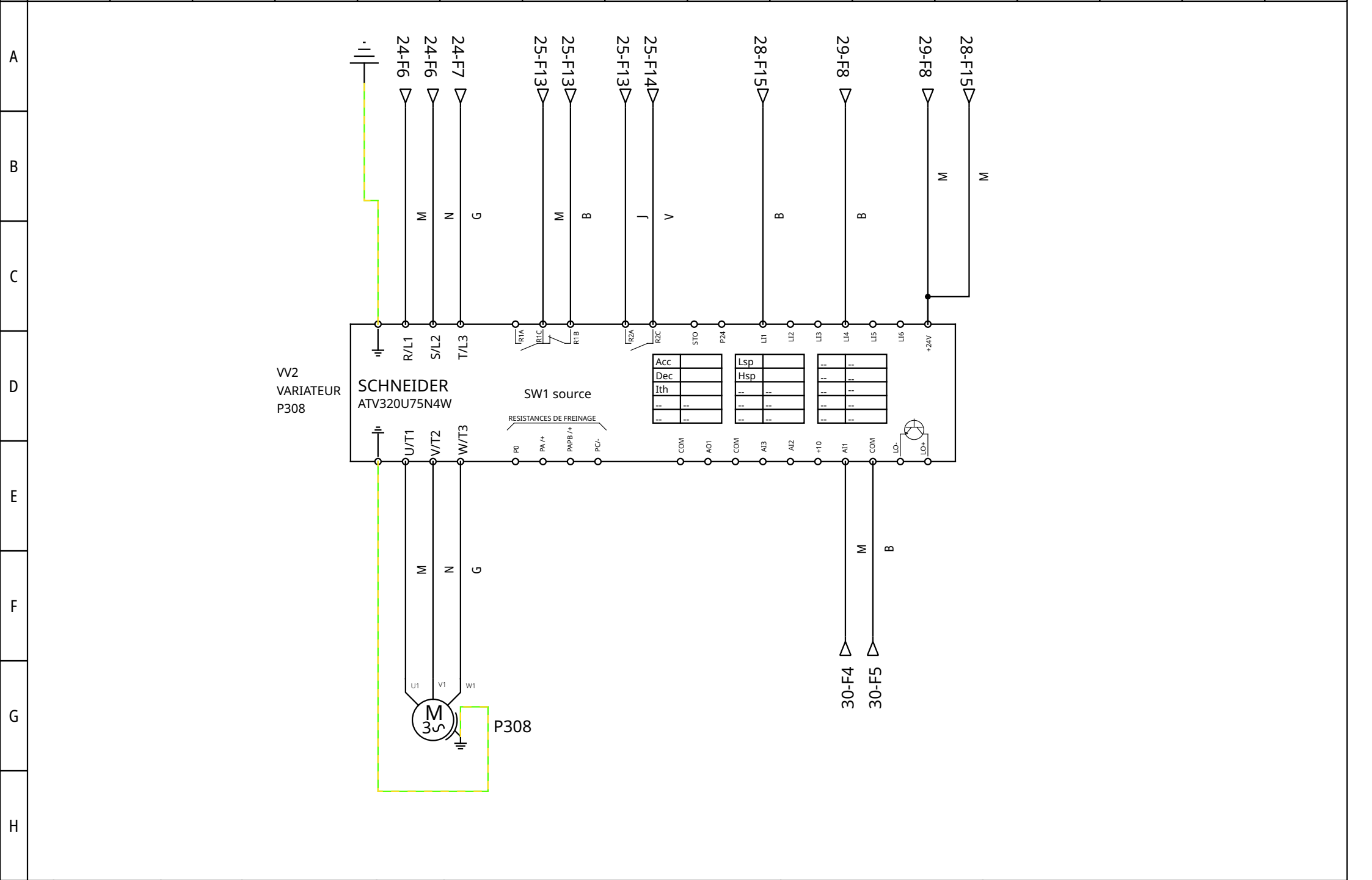

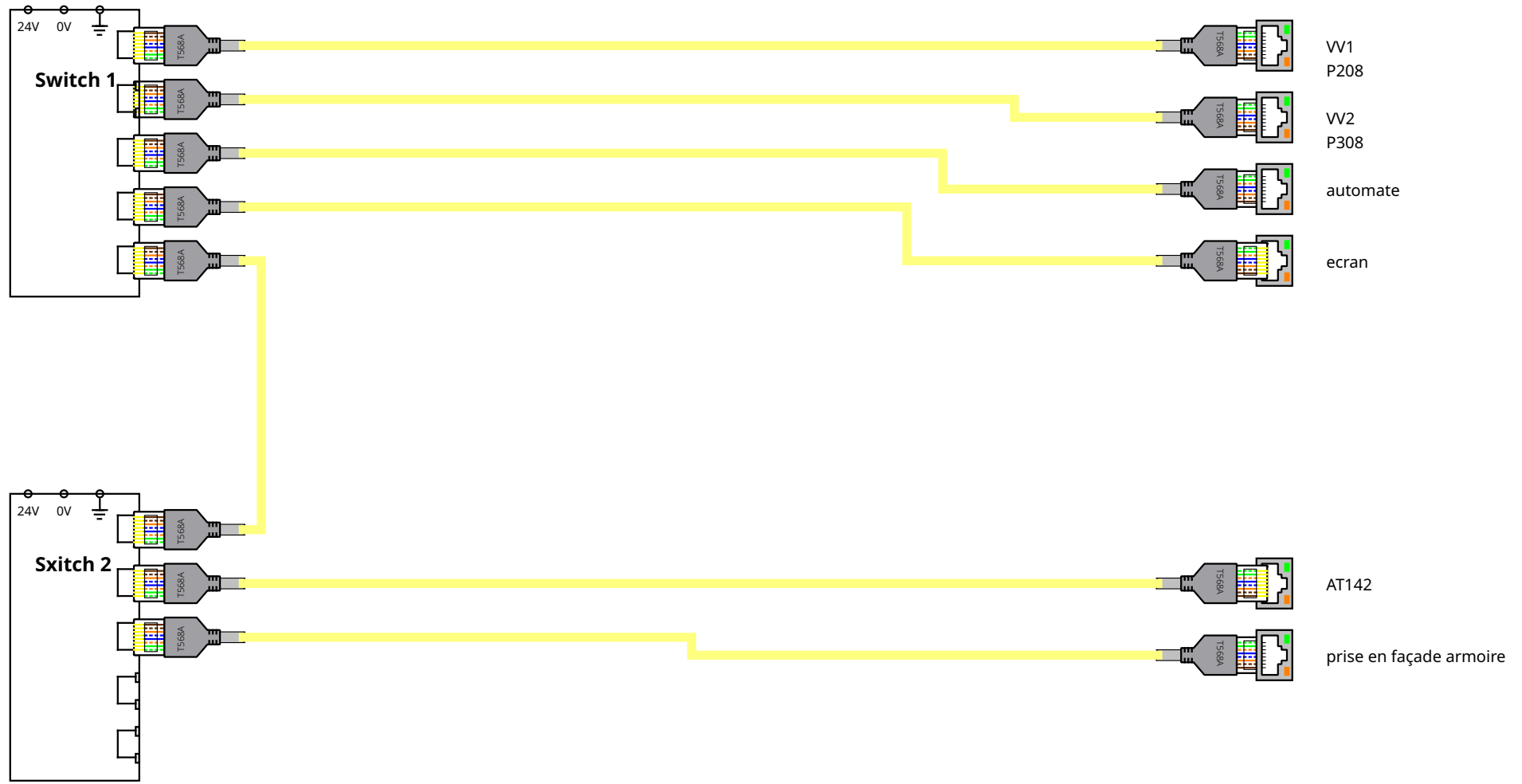

			29/07/2019	
0	EMIS		DESSINE	LC
REV	MODIFICATION	29/07/2019	APROUV	SP



détails switches

I0002188751	
osmose 2X9m3/h	Folio : 34
	Folio : 34