

Auteur : L-T
 Date : 07/02/2019

PUISSANCE

Fichier : STROMAB TR 600
 Folio : 3/7

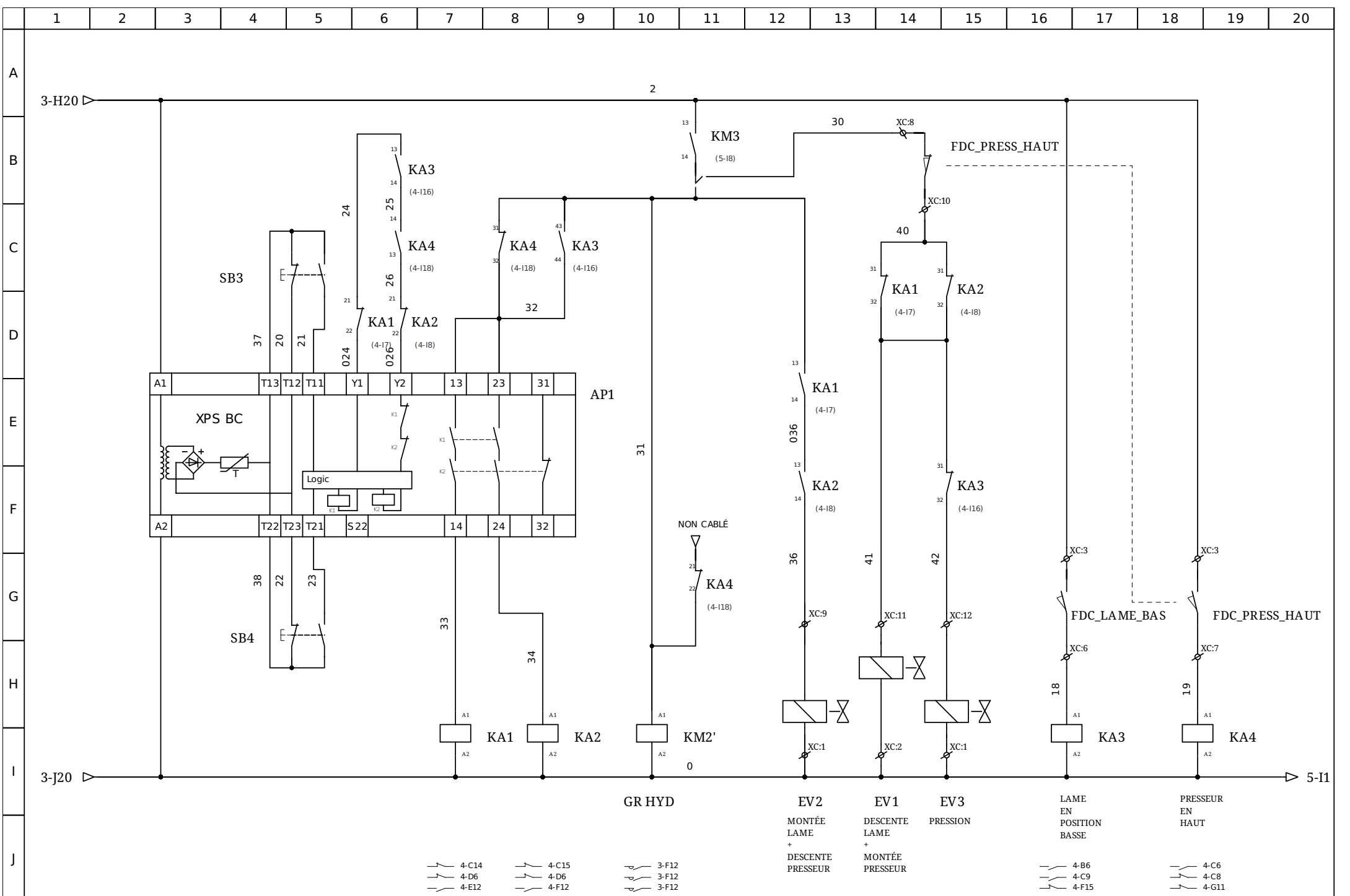

- 4-C14
- 4-D6
- 4-E12
- 4-C15
- 4-D6
- 4-F12

- 3-F12
- 3-F12
- 3-F12

- EV2
MONTÉE LAME + DESCENTE PRESSEUR
- EV1
DESCENTE LAME + MONTÉE PRESSEUR
- EV3
PRESSION

- 4-B6
- 4-C9
- 4-F15
- 4-C6
- 4-C8
- 4-G11

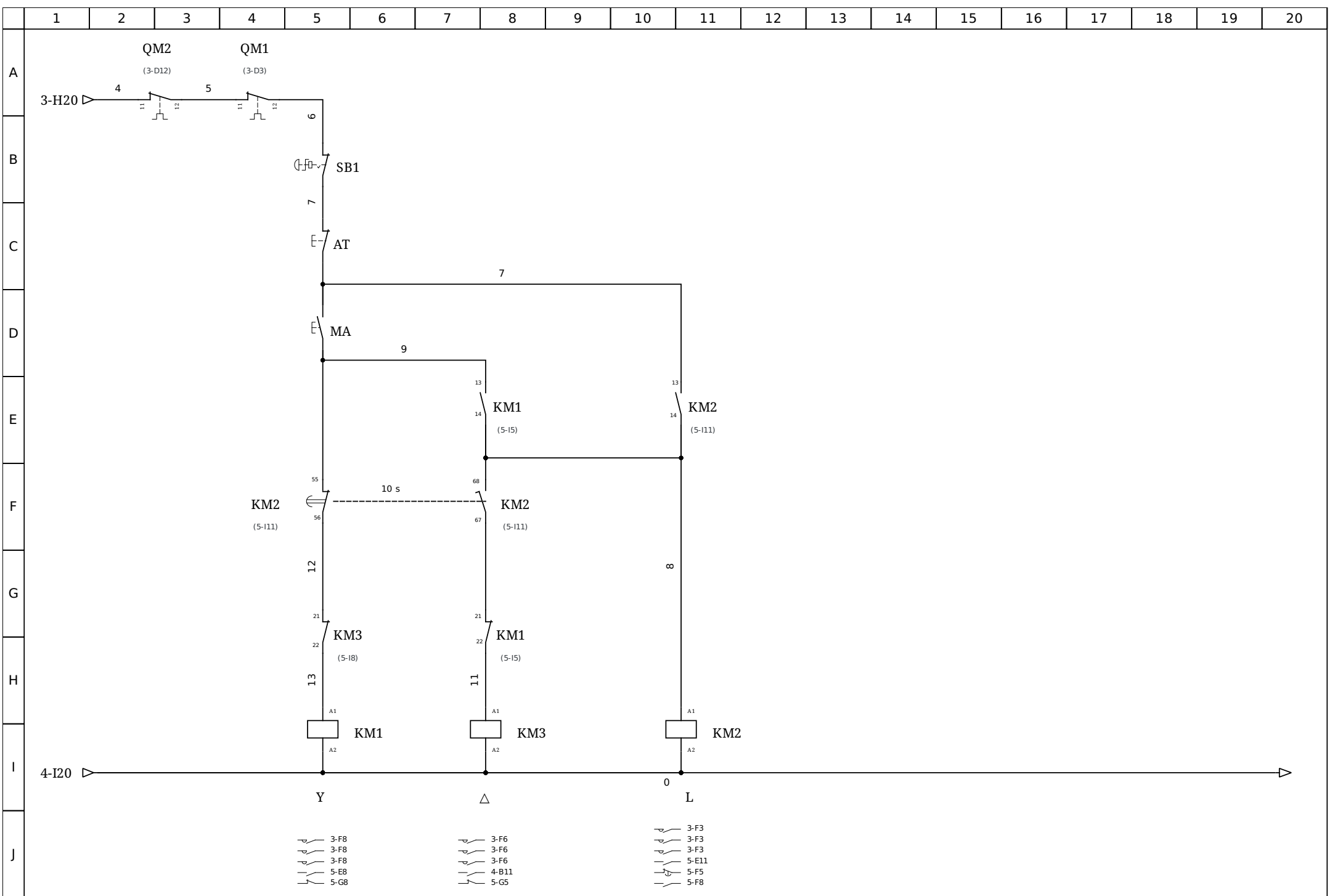

A																				
B																				
C																				
D																				
E																				
F																				
G																				
H																				
I																				
J																				

